

HURLSTONE AGRICULTURAL HIGH SCHOOL

2007

TRIAL HIGHER SCHOOL CERTIFICATE EXAMINATION

General Mathematics

Examiners: Mr. S. Faulds, Mr. G. Rawson, Mrs. S. Hackett

General Instructions

- Reading Time – 5 minutes
- Working Time – 2½ hours
- Write using blue or black pen.
- A Formulae Sheet is provided which may be used throughout the paper.
- Board approved calculators may be used.

Students are advised that this is a trial examination only and cannot in any way guarantee the content or the format of the 2007 HSC General Mathematics Examination.

Student Name:

Class Teacher:

Total Marks – 100**Section 1** 22 marks

- Attempt questions 1 – 22
- Answer on the Multiple Choice Answer Sheet provided.
- Allow about 30 minutes for this section.

Section 2 78 marks

- Attempt questions 23 – 28
- Answer each question in a separate answer booklet. An answer booklet must be handed in for each question, even if it is not attempted.
- A graph has been provided for question 28 (b). Hand in this graph with your answers for question 28.
- Allow about 2 hours for this section.

Section 1**Total marks (22)****Attempt Questions 1-22****Allow about 30 minutes for this section**

Use the multiple choice answer sheet.

Select the alternative A, B, C or D that best answers the question. Fill in the response oval completely.

Sample $2 + 4 = ?$ (A) 2 (B) 6 (C) 8 (D) 9A B C D

If you think you have made a mistake, put a cross through the incorrect answer and fill in the new answer.

A B C D If you change your mind and have crossed out what you consider to be the correct answer, then indicate this by writing the word *correct* and drawing an arrow as follows:A B C D
correct ↖

1. Simplify: $8a - (a - 5b)$
- (A) $7a + 5b$ (B) $7a - 5b$ (C) $7 + 5b$ (D) $7 - 5b$

2.

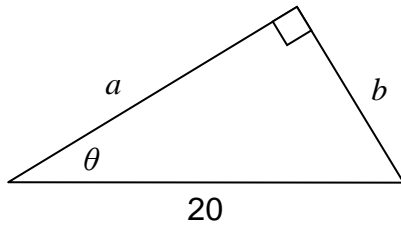
If $\sin \theta = 0.6$, then:

- (A) $a = 12$
- (B) $a = 25$
- (C) $b = 12$
- (D) $b = 25$

NOT TO SCALE

Use the following table to answer questions 3 and 4.

A survey of family size

No. of Children	No. of families
0	2
1	3
2	4
3	2
4	1

3. What is the relative frequency that a family contained 3 children?
- (A) $\frac{1}{5}$ (B) $\frac{2}{5}$ (C) $\frac{1}{6}$ (D) $\frac{1}{12}$
4. The mean number of children per family is closest to:
- (A) 1 (B) 2 (C) 3 (D) 4
5. Given that $s = ut - \frac{1}{2}at^2$, find the value of s given $u = 8$, $t = 4$ and $a = 3$.
- (A) 8 (B) 12 (C) 48 (D) 60
6. The selling price of a new car, including 10% GST, is \$27 990. The value, to the nearest \$, of the GST included in this price is
- (A) \$2544 (B) \$2799 (C) \$2545 (D) \$2800

7. On their daughter's first birthday, Peter and Jennifer invest \$1000 into an annuities fund with an interest rate of 6% p.a. If they continue to invest the same amount on each successive birthday, the amount of the investment immediately following their daughter's 21st birthday will be:

- (A) \$36 785.59 (B) \$39 992.73 (C) \$53 435.59 (D) \$56 642.73

8. The back to back stem-and-leaf plots have the same median.

1 1	4	3 4
7 4 4 3 2	5	1 3 5
7 5 4 3 1	6	1 1 3 □
9 9 7 2	7	2 2 3 4
3 2 1	8	1 2 3

The value of □ is:

- (A) 4 (B) 64
(C) 5 (D) 65

9.

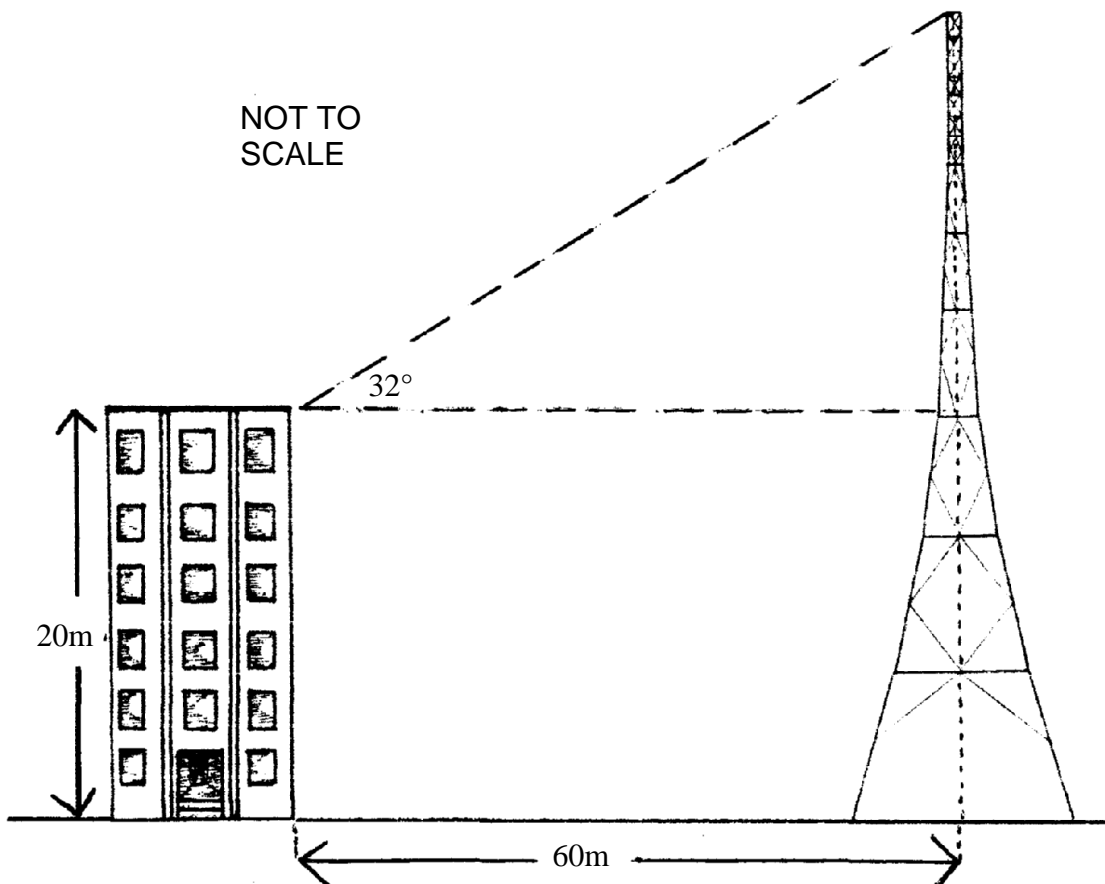

The diagram shows a building and a communications tower, 60 metres apart. The building is 20 metres high. From the top of the building, the angle of elevation of the top of the tower is 32°. The height of the tower is closest to:

- (A) 31m (B) 37m (C) 51m (D) 57m

10. A gardening expert recommends 12 litres of water per week for each 1 metre height of a certain species of native shrub. A garden hose fills an 8 litre bucket in 30 seconds.
- The time that should be spent each week watering a 6 metre high tree with the hose is:
- (A) 4.5 min (B) 6 min (C) 9 min (D) 36 min

Use the following Notebook Entry from a transverse survey to answer Questions 11 and 12.

	E	
D 36	60	
C 24	45	
	20	32 B
	0	
	A	

11. The distance from C to D is closest to:
- (A) 12m (B) 15m (C) 19m (D) 27m
12. The area of the entire field is:
- (A) 1206m^2 (B) 1284m^2 (C) 2910m^2 (D) 1950m^2

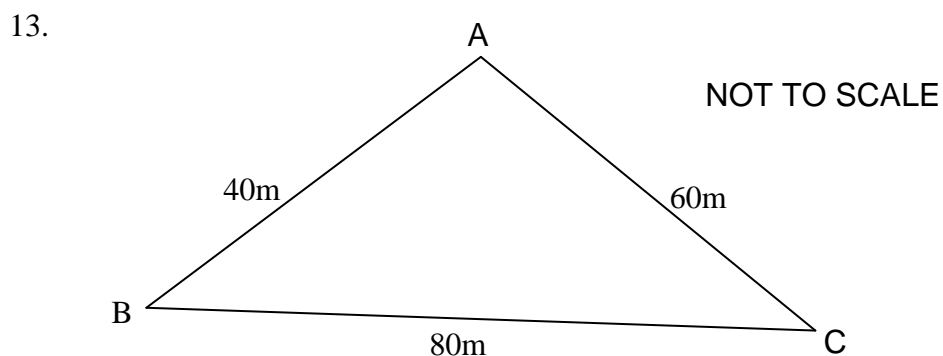

The size of the angle at B, correct to the nearest degree, is

- (A) 29° (B) 47° (C) 76° (D) 104°

14. The following table shows the monthly repayments on a personal loan over 20 years.

Amount Borrowed	Rate of Interest		
	5%	6%	7%
\$	\$	\$	\$
5 000	33.00	35.82	38.76
10 000	66.00	71.64	77.53
15000	98.99	107.46	116.29
20 000	131.99	143.29	135.06

The total interest paid on a loan of \$10 000 over 20 years at 6% p.a. is:

- (A) \$5840.00 (B) \$7193.60 (C) \$15840.00 (D) \$17193.60
- 15.

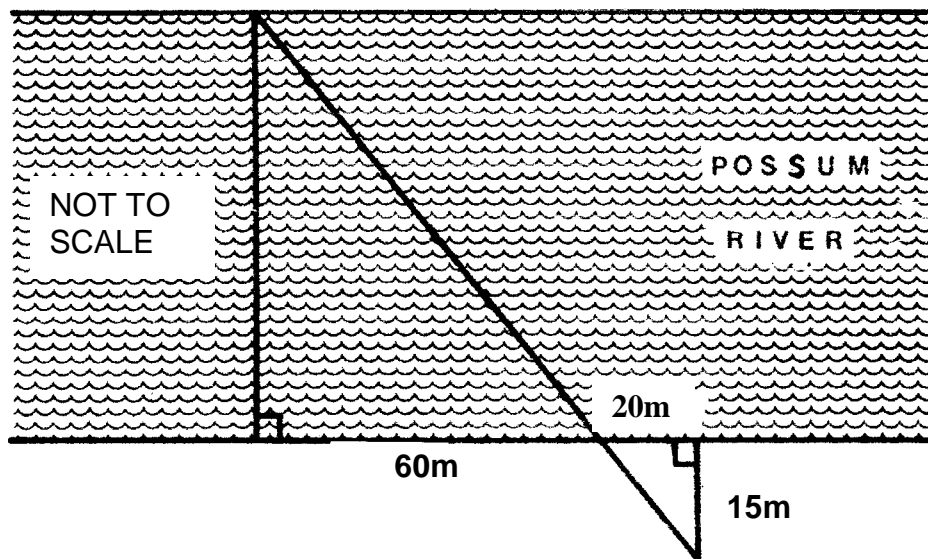

To find the width of Possum River, the measurements shown were made. The width of the river is:

- (A) 45m (B) 60m (C) 70m (D) 80m

16. The box and whisker plots shown below compare the marks of students in two classes. Which of the following statements is correct?

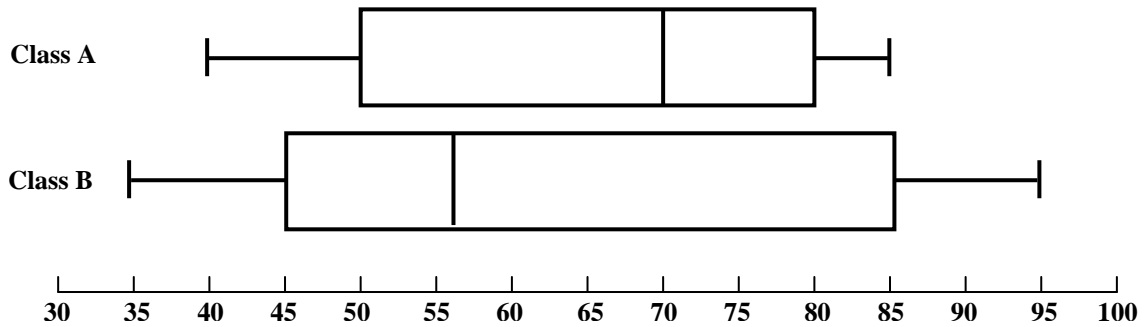

Which of the following is correct?

- (A) The median of Class B is greatest. (B) Class A is positively skewed
 (B) The range of Class B is smallest. (D) Class A is negatively skewed
17. The following diagram shows the dimensions of a rectangle correct to nearest millimetre.

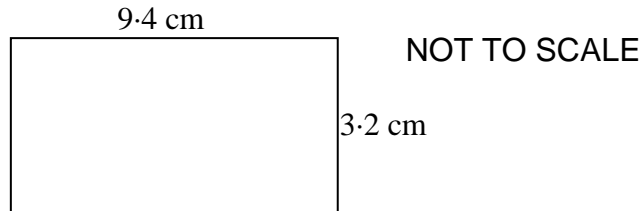

The true area of the rectangle would lie between:

- (A) 29.77cm^2 and 30.71cm^2 (B) 29.45cm^2 and 30.71cm^2
 (C) 29.45cm^2 and 30.39cm^2 (D) 29.77cm^2 and 30.39cm^2
18. A section of a wage sheet of a small business shows one employee's details.

Payee	Rate / hour	Normal Hours	Overtime		Wage
			$1\frac{1}{2} \times$	$2 \times$	
Pi General	\$	36	4	6	\$685.80

The hourly rate of pay that Pi receives is:

- (A) \$12.70 (B) \$12.82 (C) \$14.91 (D) \$19.05

19.

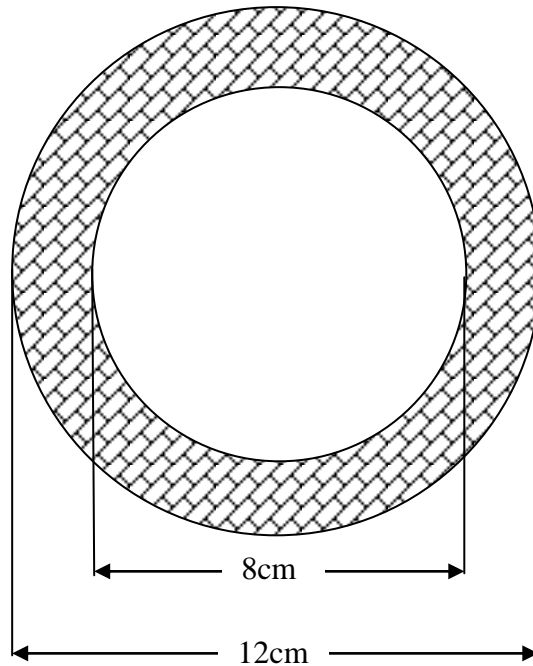
NOT TO
SCALE

Which of the following expressions will give the area, in square centimetres, of the cross-section (shaded area) of the pipe?

- (A) $\pi(12 - 8)^2$ (B) $\pi(12^2 - 8^2)$ (C) $\pi(6 - 4)^2$ (D) $\pi(6^2 - 4^2)$

20. The solution to the equation $7 - 2(x - 4) = 25$ is

- (A) $x = -7$ (B) $x = -5$ (C) $x = 5\frac{4}{5}$ (D) $x = 9$

21. The number of possible arrangements of the letters in the word GENERAL is:

- (A) 21 (B) 42 (C) 2520 (D) 5040

22. A share is valued at \$6.45. Garry buys 950 shares and at the end of the financial year Garry receives a dividend of \$257.20. The dividend yield on Garry's investment is

- (A) 0.025% (B) 0.042% (C) 2.5% (D) 4.2%

Section II

Total Marks (78)

Attempt Questions 23 - 28

Allow about 2 hours for this section.

Answer all questions, starting each question on a new sheet of paper with your name and question number at the top of the page. Do not write on the back of sheets.

Question 23 (13 marks) Start a new sheet of paper.
Marks

- (a) A field is bordered by three straight sides and a river, as shown.

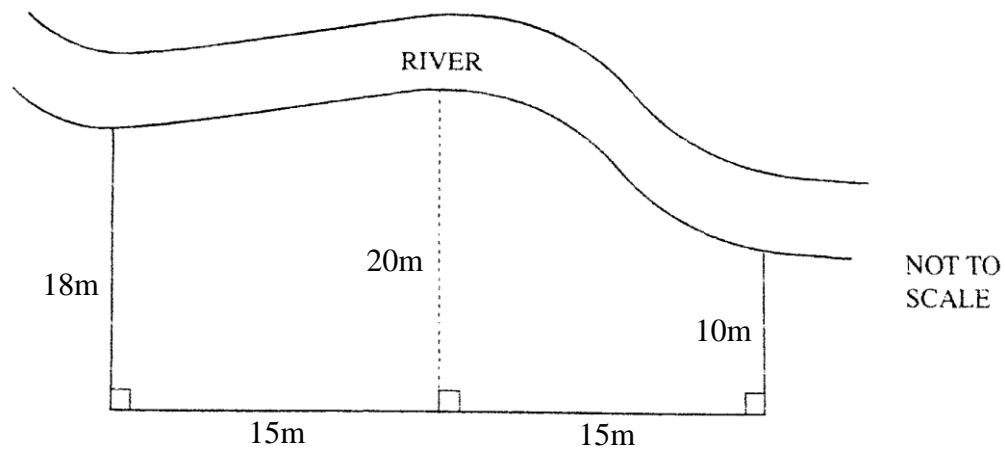

- (i) Use Simpson's Rule to find the area of the field. 2
- (ii) The field is to be top dressed to a height of 10cm. Find the cost of topsoil required at \$15.60 per cubic metre. 2
- (b) Solve $\frac{2x-3}{4} + 5 = 9$ 3
- (c) A loan of \$290 000 at 6% p.a. compounded monthly is paid off in equal monthly instalments over a 20 year term. Calculate the total cost of the loan. 3
- (d) On the day of their daughters birth, Michelle and Greg decide to start investing money so that they can give their daughter \$25 000 on her 21st Birthday. They receive 5% p.a. interest. Calculate the present value of the investment needed to achieve this goal. 2
- (e) Convert 0.046m^2 to cm^2 . 1

Question 24 (13 marks) Start a new sheet of paper.

Marks

(a) The following survey of a field was recorded.

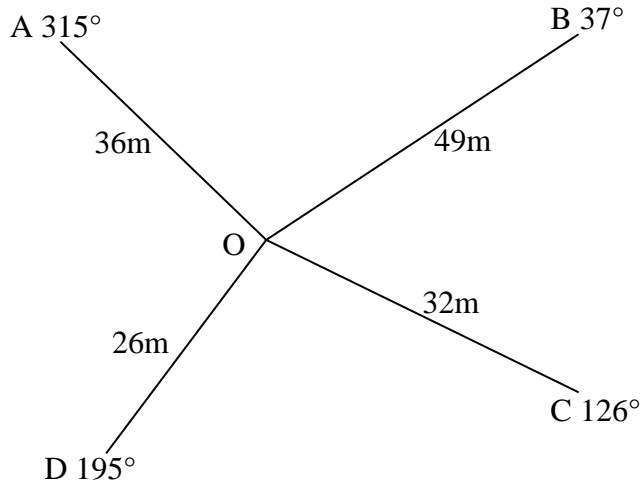

- (i) Find the size of angle AOB. **1**
- (ii) Find the area of the triangle AOB. (Answer to 1 dec. pl.) **2**
- (iii) Find the distance between A and B. (Answer to 1 dec. pl.) **2**

(b) The following two-way table shows the results of a survey on the use of sunscreen and obtaining a melanoma.

	Use Sunscreen	Don't use Sunscreen	Totals
Had a Melanoma during past year	14	?	60
No Melanoma during past year	?	4	?
Totals	60	50	?

- (i) Copy the table into your answer booklet and fill in the missing entries. **1**
- (ii) What percentage of people use sunscreen? **1**
- (iii) What is the probability that a person surveyed used sunscreen and didn't have a melanoma during the last year? **1**
- (iv) "Using sunscreen prevents a person from obtaining a melanoma"
Comment on the above statement. **1**

Question 24 continued on next page.

Question 24 (continued)

Marks

- (c) Five different sporting trophies were to be displayed on a shelf. In how many different ways can the trophies be arranged on the shelf if the swimming trophy is to occupy the centre position? Show working to justify your answer. **2**
- (d) The graph shows the average cost of producing a doll in a factory.

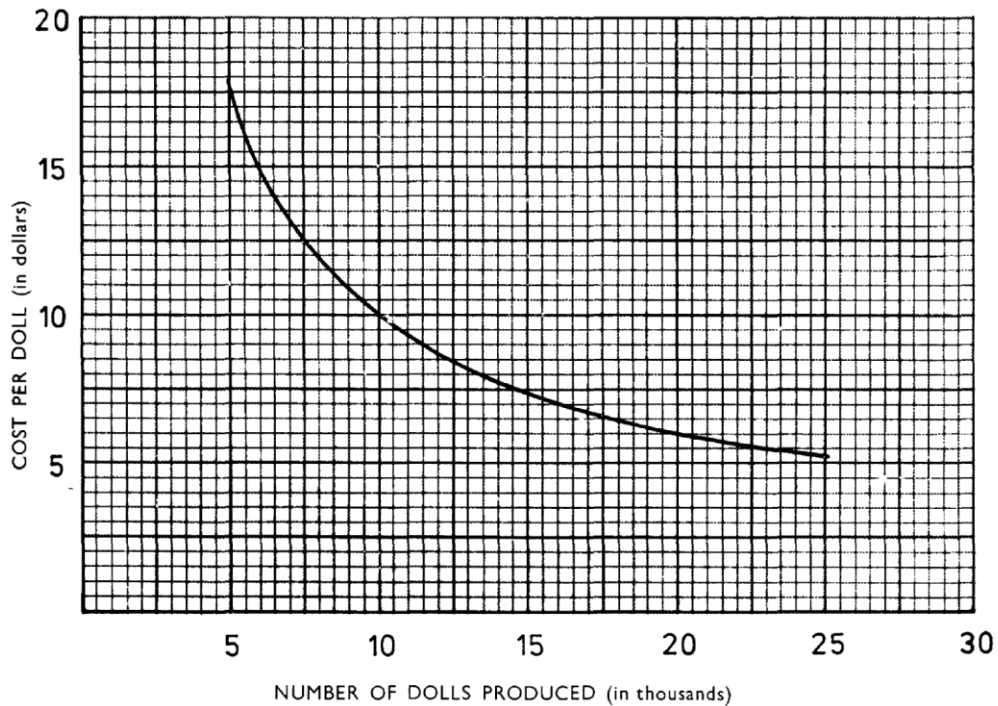

- (i) In 2007 the average production cost per doll was \$11. Find the number of dolls produced that year? **1**
- (ii) If the company produced 7500 dolls, what was average production cost per doll for that year? **1**

Question 25 (13 marks) Start a new sheet of paper.

Marks

- (a) A bird cage contains 12 budgerigars. Six of the birds are blue, five are green and one is yellow. Two of the budgerigars are selected at random.

- (i) Draw a probability tree to show all possible outcomes for the colours of the chosen birds. **1**

What is the probability that:

- (ii) a blue and a yellow budgerigar will be chosen? **2**
(iii) both budgerigars will be the same colour? **2**
(iv) at least one of the chosen birds is not green? **2**

- (b) The diagram of a closed metal water tank is shown below. The tank has a hole in the top to allow rainfall in. The area of this hole is 0.6 square metres.

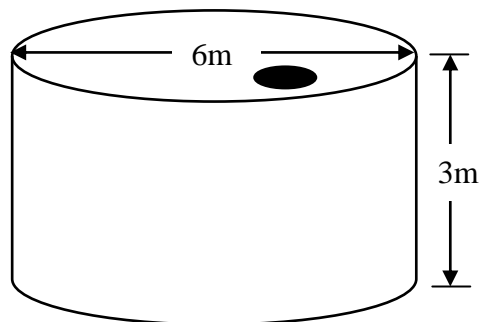

- (i) Calculate the amount of metal used to construct the tank. Answer to the nearest m^2 **2**
(ii) Find the volume of the tank in cubic metres. **2**
(iii) If a particular household uses 1500 litres per week, how many weeks of water does the tank hold, assuming that there is no rain? **2**

Question 26 (13 marks) Start a new sheet of paper.

Marks

(a)

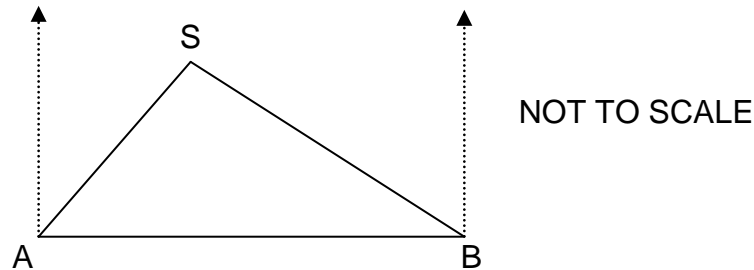

Two towers are located on a beach at positions A and B. A is 40 m due west of B. A swimmer in trouble (at S) is sighted by a lifeguard at A and is located in a direction 043° T. At the same time the lifeguard at B spots the same swimmer at a bearing of 296° T.

- (i) Copy the diagram into your answer booklet, marking on it all the relevant information. 1
- (ii) Find the size of the angle ASB. 1
- (iii) How far is the swimmer from B? (Answer correct to 2 dec. pl.) 2

(b) The following box and whisker plot shows the results that a class of 20 students achieved on their English test.

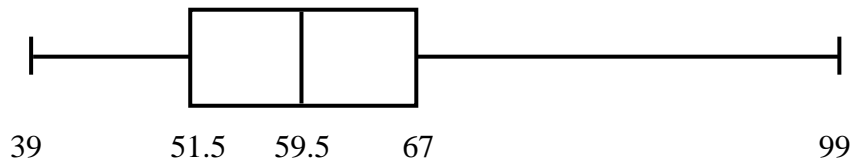

- (i) What is the range of the scores? 1
- (ii) Calculate the interquartile range. 1

The results from the same class of students on a mathematics test are displayed in the following stem and leaf plot.

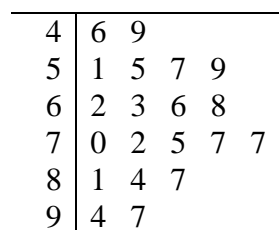

- (iii) Find the median, lower quartile, upper quartile and the interquartile range for these results. 4
- (iv) If James scored 75 in Maths and 70 in English, which is the better mark, relative to the class results? Justify your answer. 2

(c) The mean of 5, -1, 4 and x is 6. Find the value of x . 1

Question 27 (13 marks) Start a new sheet of paper.

Marks

- (a) A car bought for \$29 990 depreciates at the rate of 18% per annum.
- (i) Use the declining balance formula to find the value of the car after 3 years? **2**
- (ii) How long will it take for the car be worth no more than \$9000? **2**
- (b) When completing her income tax return for the 2006/07 financial year, Martina calculated that her gross income from all sources was \$93 846. She had work related tax deductions of \$879 and other allowable deductions of \$3 112.
- (i) Show that Martina's taxable income was \$89 855. **1**
- (ii) Using the tax table below, calculate the income tax that Martina must pay. **2**

<i>Taxable income</i>	<i>Tax on this income</i>
\$0 – \$6,000	Nil
\$6,001 – \$25,000	15c for each \$1 over \$6,000
\$25,001 – \$75,000	\$2,850 plus 30c for each \$1 over \$25,000
\$75,001 – \$150,000	\$17,850 plus 40c for each \$1 over \$75,000
\$150,001 and over	\$47,850 plus 45c for each \$1 over \$150,000

- (iii) The Medicare Levy is calculated as 1.5% of taxable income. What amount will Martina pay for her Medicare for the 2006/07 year? **1**
- (c) In a certain game, two dice are rolled and the product of the 2 numbers turned up is calculated. If this total is 10 or greater the player wins \$5. If the total is between 6 and 9 inclusive the cost of playing the game is returned. It costs a player \$2 to have a turn. What is the financial expectation for the game? **3**
- (d) A dishwasher has a cash price of \$799. Mr Clean agreed to buy it, making a deposit of \$150 and monthly repayments of \$35 over two years. What is the flat rate of interest p.a. being charged on the balance? **2**

Question 28 (13 marks) Start a new sheet of paper.

Marks

(a)

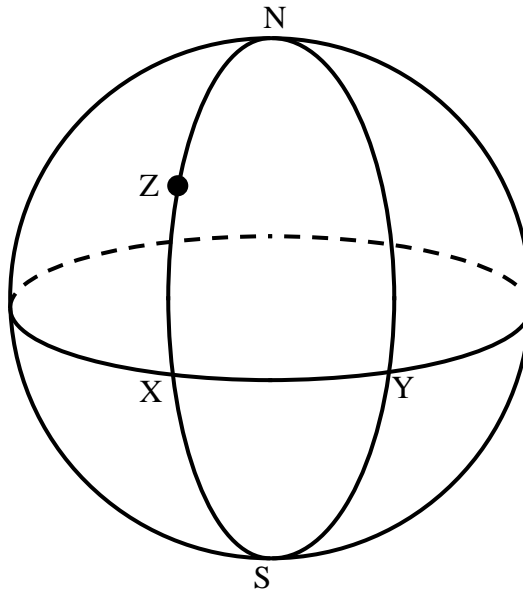

In the diagram above, X and Y represent points on the equator with longitudes 70° W and 30° E respectively. Z is located on latitude 40° N with longitude 70° W.

- | | | |
|-------|---|----------|
| (i) | What is the angular distance between X and Z. | 1 |
| (ii) | Find the distance between X and Y along the Earth's surface in Nautical Miles. | 2 |
| (iii) | How long does it take a ship travelling at 60 knots to travel from X to Y. | 1 |
| (iv) | If the ship leaves X at 6am Monday 1 st August, what time and day does the ship arrive at Y? | 2 |

Question 28 continued on next page.

Question 28 (continued)**Marks**

- (b) For a fund raising event, Roger and Maria are planning a concert and have secured the services of two bands provided they pay their transport costs of \$500. A venue has also been booked for the cost of the cleaning fee which is \$250. They plan to provide light refreshments at a cost of \$10 per person.

The graph provided shows the costs associated with the concert using the information above.

- (i) Write a formula for the cost (\$C) of running the concert for x people. **1**
- (ii) On the same graph, draw the line which represents concert income (\$I) if the ticket price is to be \$15. **1**
- (iii) Use the graph to determine the number of people required for the concert to break even. (ie. where income covers costs.) **1**
- (iv) What will be the profit from the concert if 250 people attend? **1**
- (v) Assume that Roger and Maria can sell 300 tickets and that they plan to make a profit of at least \$1000. **3**

What will be the *minimum* price that Roger and Maria should charge for each ticket? (Answer to the nearest cent.)

End of Examination

Formulae Sheet

Area of an annulus

$$A = \pi(R^2 - r^2)$$

R = radius of outer circle

r = radius of inner circle

Area of an ellipse

$$A = \pi ab$$

a = length of semi-major axis

b = length of semi-minor axis

Area of a sector

$$A = \frac{\theta}{360} \pi r^2$$

θ = number of degrees in central angle

Arc length of a circle

$$l = \frac{\theta}{360} 2\pi r$$

θ = number of degrees in central angle

Surface area of a sphere

$$A = 4\pi r^2$$

Simpson's rule for area approximation

$$A \approx \frac{h}{3}(d_f + 4d_m + d_l)$$

h = distance between successive measurements

d_f = first measurement

d_m = middle measurement

d_l = last measurement

Volume

Cone $V = \frac{1}{3} \pi r^2 h$

Cylinder $V = \pi r^2 h$

Pyramid $V = \frac{1}{3} Ah$

Sphere $V = \frac{4}{3} \pi r^3$

A = area of base

h = perpendicular height

Mean of a distribution

$$\bar{x} = \frac{\sum x}{n}$$

$$\bar{x} = \frac{\sum fx}{\sum f}$$

x = individual score

\bar{x} = mean

Formula for z-scores

$$z = \frac{x - \bar{x}}{s}$$

s = standard deviation

Probability of an event

The probability of an event where outcomes are equally likely is given by:

$$P(\text{event}) = \frac{\text{number of favourable outcomes}}{\text{total number of outcomes}}$$

Simple interest

$$I = Prn$$

P = initial quantity

r = percentage interest rate per period
expressed as a decimal

n = number of periods

Compound interest

$$A = P(1 + r)^n$$

A = final balance

P = initial quantity

n = number of compounding periods

r = percentage interest rate per
compounding period expressed as a
decimal

Future value (A) of an annuity

$$A = M \left\{ \frac{(1+r)^n - 1}{r} \right\}$$

M = contribution per period, paid at the end
of the period

Present value (N) of an annuity

$$N = M \left\{ \frac{(1+r)^n - 1}{r(1+r)^n} \right\}$$

or

$$N = \frac{A}{(1+r)^n}$$

Straight-line formula for depreciation

$$S = V_0 - Dn$$

S = salvage value of asset after n periods

V_0 = purchase price of the asset

D = amount of depreciation apportioned
per period

n = number of periods

Declining balance formula for depreciation

$$S = V_0(1 - r)^n$$

S = salvage value of asset after n periods

r = percentage interest rate per period,
expressed as a decimal

Sine rule

$$\frac{a}{\sin A} = \frac{b}{\sin B} = \frac{c}{\sin C}$$

Area of a triangle

$$A = \frac{1}{2}ab \sin C$$

Cosine rule

$$c^2 = a^2 + b^2 - 2ab \cos C$$

or

$$\cos C = \frac{a^2 + b^2 - c^2}{2ab}$$

Gradient of a straight line

$$m = \frac{\text{vertical change in position}}{\text{horizontal change in position}}$$

Gradient–intercept form of straight line

$$y = mx + b$$

m = gradient

b = y-intercept

Multiple Choice Answer Sheet

Student Name/Number _____

Completely fill the response oval representing the most correct answer.

- 1. A B C D
- 2. A B C D
- 3. A B C D
- 4. A B C D
- 5. A B C D
- 6. A B C D
- 7. A B C D
- 8. A B C D
- 9. A B C D
- 10. A B C D
- 11. A B C D
- 12. A B C D
- 13. A B C D
- 14. A B C D
- 15. A B C D
- 16. A B C D
- 17. A B C D
- 18. A B C D
- 19. A B C D
- 20. A B C D
- 21. A B C D
- 22. A B C D

Student Name/Number _____

Use this graph for Question 28(b).

Hand in the graph with your solutions to Question 28.

