

Multiple choice

1. How many arrangements of the letters in the word **banana** are there?

- A** 720 **B** 120 **C** 60 **D** 30

2. What is the remainder when the polynomial $x^3 - 2x^2 - 4x + 7$ is divided by $(x + 3)$?

- A** 4 **B** -22 **C** -26 **D** -50

3. What is the exact value of $\sin^{-1}\left(-\frac{\sqrt{3}}{2}\right)$?

- A** $-\frac{\pi}{6}$ **B** $-\frac{\pi}{3}$ **C** $\frac{5\pi}{6}$ **D** $\frac{11\pi}{12}$

4. What is $\lim_{h \rightarrow 0} \frac{\cos\left(\frac{3\pi}{2} + h\right) - \cos\left(\frac{3\pi}{2}\right)}{h}$?

- A** 1 **B** $\frac{\sqrt{2}}{2}$ **C** 0 **D** -1

5. What is the period of motion for a particle which is moving should that $v^2 = 25 - 2x^2$?

- A** $\sqrt{2}$ **B** 2 **C** $\frac{\pi}{\sqrt{2}}$ **D** $\sqrt{2}\pi$

6. What is the value $\sin 2\theta$, given $\sin \theta = \frac{3}{5}$ and $\sin \theta > 0$?

- A** $\frac{6}{5}$ **B** $\frac{24}{25}$ **C** $\frac{4}{5}$ **D** $\frac{12}{25}$

7. In the figure below, AD is a diameter of the circle with centre O and $AO = 5$.

What is the length of arc BCD?

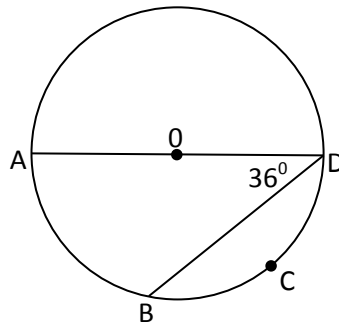

- A** $\frac{\pi}{2}$ **B** π **C** 3π **D** $\frac{7\pi}{2}$

8. The constant term of $\left(x - \frac{2}{x}\right)^8$ is

- A** 256 **B** 448 **C** 896 **D** 1120

9. Which expression best represents the primitive function for $y = \cos^2 x$.

- A** $\frac{1}{4} \sin 2x + \frac{x}{2} + c$ **B** $\frac{1}{2} (\sin 2x + x) + c$
C $\frac{1}{4} \sin^2 x + c$ **D** $\frac{1}{4} \sin 2x - \frac{x}{2} + c$

10. The value of $\int_0^1 \cos^{-1} x dx$ is

- A** 0 **B** 1 **C** $\frac{\pi}{2} - 1$ **D** $\frac{\pi}{2}$

Question 11 (15 marks)

- (a) Find the coordinates of the point that divides the interval A (-2, 7) B (12, 0) externally in the ratio 4:3. **2**
- (b) Find $\int_{-2}^2 \frac{dx}{4+x^2}$ **2**
- (c) Solve $\frac{2x-3}{x-1} \leq 4$. **3**
- (d) Evaluate $\int_0^5 x\sqrt{25-x^2} dx$ using the substitution $u = 25-x^2$ **4**
- (e) Evaluate $\lim_{x \rightarrow 0} \frac{\sin\left(\frac{3x}{4}\right)}{2x}$ **2**
- (f) Find the domain and range for the function $y = 5\sin^{-1}\left(\frac{x}{\pi}\right)$. **2**

Question 12 (15 marks) Start this question in a new booklet.

- (a) For the function $f(x) = \sin x - \cos^2 x$, starting with $x_1 = 2.2$ use one application of Newton's method to find a better approximation for the root. Answer correct to 2 significant figures. **3**
- (b) Find the vertex of the parabola represented by the parametric equations below: **3**
- $$x = 2t + 1$$
- $$y = t^2 - 2t$$
- (c) When Andy and Roger play tennis, Andy has a 0.3 chance of winning any particular game. On the weekend they intend to play 6 games. Calculate the probability (to 2 significant figures) that :
- (i) Roger wins no games. **1**
- (ii) Roger wins at least one game. **1**
- (iii) Roger wins 4 or more games. **3**

Question 12 continued

Marks

- (d) A bottle of milk which is initially at a temperature of 4°C is placed into a room which has a constant temperature of 25°C . The milk warms at a rate proportional to the difference between the temperature of the room and the temperature (T) of the milk. That is, T satisfies the equation $\frac{dT}{dt} = -k(T - 25)$.
- (i) Show that $T = 25 + Ae^{-kt}$ satisfies this equation. **1**
- (ii) If the temperature of the medicine after ten minutes is 12°C , find its temperature after 40 minutes. **3**

Question 13 (15 marks) Start this question in a new booklet.

- (a) A surveyor who is y metres south of a tower sees the top of it with an angle of elevation 6° . A second surveyor is x metres east of the tower. From his position the angle of elevation is 10° to the top of the tower. The two surveyors are 860m apart.
- (i) Show that $y = h \cot 6^{\circ}$ **1**
- (ii) Find the height of the tower to the nearest metre. **4**

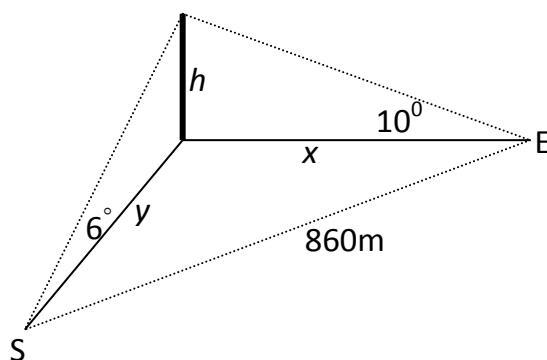

Question 13 continued**Marks**

- (b) A particle P is moving in a straight line with its position in metres from a fixed origin at a time t seconds being given by

$$x = -4 \sin\left(2t - \frac{\pi}{3}\right).$$

- (i) Show that P is moving in simple harmonic motion. **2**
- (ii) What is the amplitude of the motion? **1**
- (iii) What is the maximum speed of the particle? **1**
- (c) Let $P(2ap, 2ap^2)$ and $Q(2aq, 2aq^2)$ be points on the parabola $y = \frac{x^2}{2a}$.
- (i) Find the equation of the chord PQ. **2**
- (ii) If PQ is a focal chord, find the relationship between p and q . **2**
- (iii) Show that the locus of the midpoint of focal chord PQ is a parabola. **2**

Question 14 (15 marks) Start this question in a new booklet.

- (a) For the cubic equation $2x^3 - 3x^2 + 5x - 4 = 0$ with roots, $x = \alpha$, $x = \beta$ and $x = \gamma$, find the value of :

- (i) $\alpha^2 + \beta^2 + \gamma^2$ **2**
- (ii) $\frac{1}{\alpha^2\beta^2} + \frac{1}{\beta^2\gamma^2} + \frac{1}{\alpha^2\gamma^2}$ **2**

Question 14 continued

Marks

(b) Use the principal of Mathematical Induction to prove that $7^n - 3^n$ is a multiple of 4 for all positive whole numbers. **3**

(c) If $(1 + x)^n = \binom{n}{0} + \binom{n}{1}x + \binom{n}{2}x^2 + \dots + \binom{n}{n}x^n$, show that: **2**

$$2 \binom{n}{2} + (2 \times 3) \binom{n}{3} + (3 \times 4) \binom{n}{4} + \dots + n(n-1) \binom{n}{n} = n(n-1) 2^{n-2}$$

(d) Two players on a basketball court, Bill is standing on the end line with the ball ready to throw to Jason, who is moving directly towards the other end of the court, away from Bill. Jason is 2m away and running at 5m/s when Bill throws the ball in the same direction as Jason is travelling. Bill throws the ball at 10m/s and at an angle of θ° to the Horizontal. Assume Jason's velocity is constant, the height at which the ball is thrown and caught is identical and $g = -10m/s^2$. The equation describing the trajectory of the ball are:

$$\ddot{x} = 0, \dot{x} = 10 \cos \theta, x = 10t \cos \theta, \ddot{y} = -10, \dot{y} = -10t + 10 \sin \theta, y = -5t^2 + 10t \sin \theta.$$

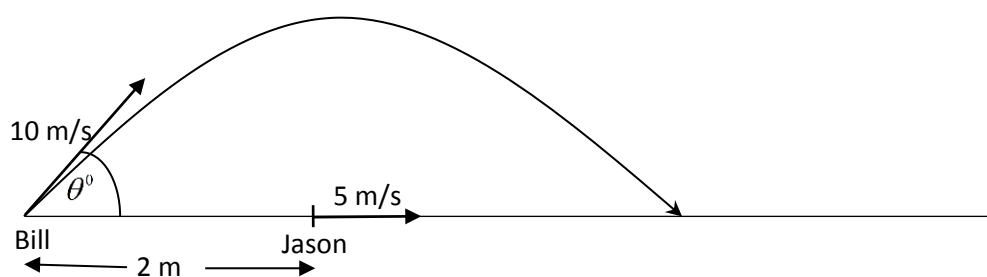

(i) Show that $20 \sin \theta \cos \theta - 10 \sin \theta - 2 = 0$ for Jason to catch the ball. **3**

(ii) Using a suitable method find approximate values for θ . **3**
Graph paper is available.

End of Paper