

SHORE

2008

Trial HSC Examination

General Mathematics

General Instructions

- Reading time – 5 minutes
- Working time – 2.5 hours
- Write using black or blue pen
- Calculators may be used
- A formulae sheet is provided at the back of this paper
- Write your examination number on the front cover of each booklet to be handed in
- If you do not attempt a question, submit a blank booklet marked with your examination number and “N/A”

Student Number:

Set:

Total marks – 100

Section I Pages 5 – 13

22 marks

- Attempt Questions 1 – 22
- Allow about 30 minutes for this section

Section II Pages 14 – 26

78 marks

- Attempt Questions 23 – 28
- Allow about 2 hours for this section

**DO NOT REMOVE THIS PAPER FROM
THE EXAMINATION ROOM**

BLANK PAGE

Section I

22 marks

Attempt Questions 1 – 22

Allow about 30 minutes for this section

Use the multiple-choice answer sheet.

Select the alternative A, B, C or D that best answers the question. Fill in the response oval completely.

Sample: $2 + 4 =$ (A) 2 (B) 6 (C) 8 (D) 9
A B C D

If you think you have made a mistake, put a cross through the incorrect answer and fill in the new answer.

A B C D

If you change your mind and have crossed out what you consider to be the correct answer, then indicate the correct answer by writing the word **correct** and drawing an arrow as follows.

A B C D
correct ↙

BLANK PAGE

1. Emma is paid \$15.75 gross an hour. She pays 28.5 cents in the dollar taxation. What is her net pay for a 25 hour week of work?
- (A) \$393.75
- (B) \$112.22
- (C) \$281.53
- (D) \$293.75
2. Simplify $8m^2c \div 4m^2c^2$
- (A) $2c$
- (B) $\frac{2}{c}$
- (C) $\frac{c}{2}$
- (D) $2m^0$
3. The following set of temperatures were recorded over 10 days.
- What is the median temperature?
- 11, 12, -2, 5, 7, 9, 4, -1, 4, 0
- (A) 4
- (B) 4.5
- (C) 5
- (D) 8
4. Find the closest value of v , for $v > 0$, given $v^2 = u^2 - 2gh$ and $u = 10$, $g = 9.8$, $h = 2$.
- (A) 7.8
- (B) 11.8
- (C) 60.8
- (D) 139.2

5. Find the area of the following ellipse.

NOT TO
SCALE

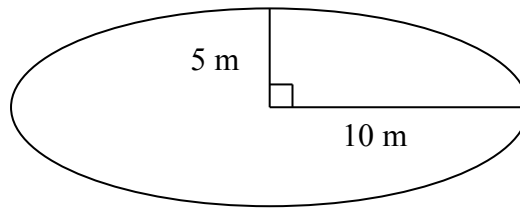

- (A) $50\pi \text{ m}^2$
- (B) $200\pi \text{ m}^2$
- (C) $300\pi \text{ m}^2$
- (D) $400\pi \text{ m}^2$
6. An expression for x in the following diagram is:

NOT TO
SCALE

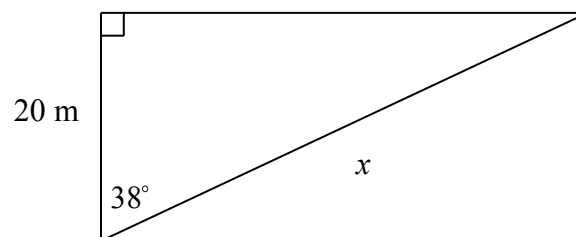

- (A) $20 \cos 38^\circ$
- (B) $\frac{\cos 38^\circ}{20}$
- (C) $\frac{20}{\cos 38^\circ}$
- (D) $20 \tan 38^\circ$

7. Find the gradient of the line AB.

NOT TO
SCALE

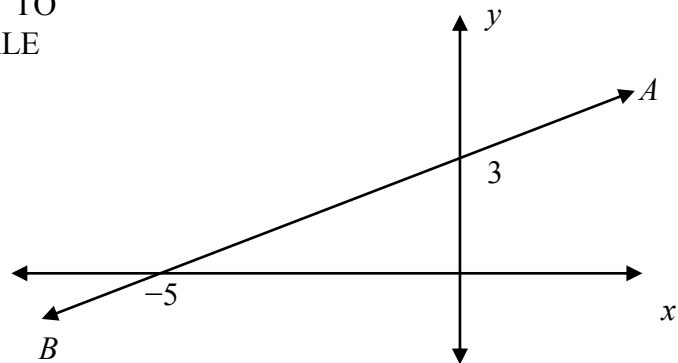

- (A) $-\frac{5}{3}$
- (B) $-\frac{3}{5}$
- (C) $\frac{3}{5}$
- (D) $\frac{5}{3}$
8. Sue plays a game in which she has:

$\frac{3}{10}$ chance of winning \$40

$\frac{1}{2}$ chance of winning \$1

$\frac{1}{5}$ chance of losing \$25

What is Sue's financial expectation when playing this game?

- (A) \$2.50
- (B) \$7.50
- (C) \$12.50
- (D) \$14.50

9. Find the cost of painting the four walls of a rectangular room represented below, given that one square metre of paint costs \$1.28.

NOT TO
SCALE

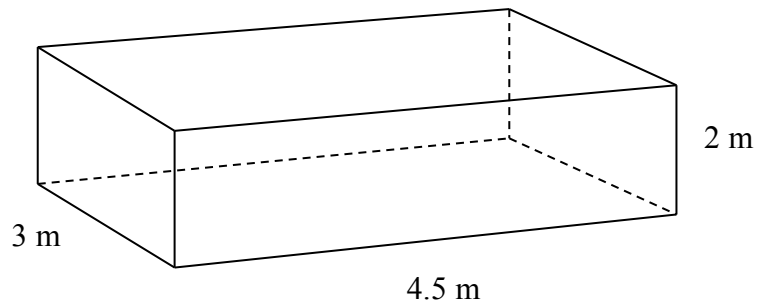

- (A) \$19.20
- (B) \$55.68
- (C) \$72.96
- (D) \$38.40
10. The solution to $\frac{2a-5}{3} = -4$ is:

- (A) $a = -8\frac{1}{2}$
- (B) $a = -3\frac{1}{2}$
- (C) $a = -\frac{2}{7}$
- (D) $a = 3\frac{1}{2}$

11. Which rate of simple interest enables \$500 invested for 10 years to amount to \$700?

- (A) 14% p.a.
- (B) 3.5% p.a.
- (C) 4% p.a.
- (D) 5.6% p.a.

12. In the following diagram, find the value of $\sin \theta$.

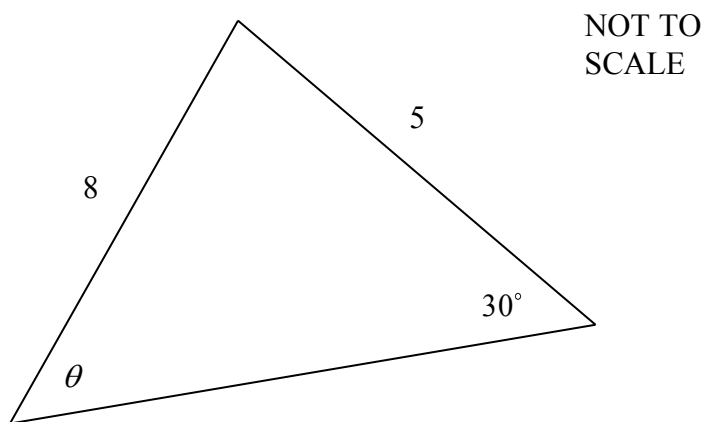

- (A) $\frac{4}{5}$
- (B) $\frac{5}{16}$
- (C) $\frac{5}{8}$
- (D) $\frac{5}{4}$

13. Six girls try out for two places on a doubles tennis team. The number of teams that can be chosen is:

- (A) 36
- (B) 30
- (C) 15
- (D) 18

14. A jacket originally selling for \$60 is reduced to \$40. A further discount of 25% is then given.

What is the total percentage discount given?

- (A) 35
 - (B) 45
 - (C) 50
 - (D) 58.3
15. The double box-and-whisker plot below shows the number of letters posted daily in an inner-city suburb compared to an outer suburb.

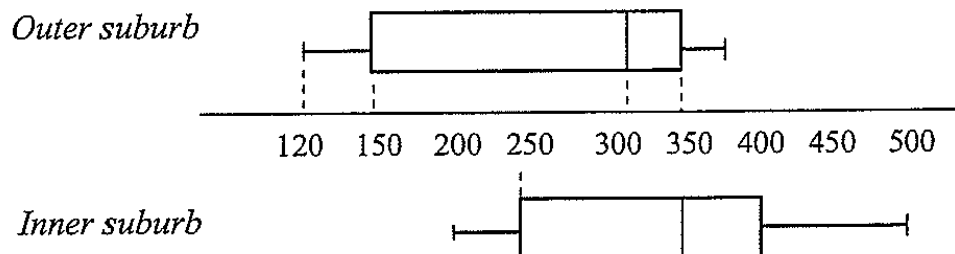

Which of the following statements correctly compares the data collected?

- (A) The median number of letters posted was the same for both suburbs.
 - (B) The letters posted from the outer suburb had a greater inter-quartile range.
 - (C) There were more letters posted from the outer city suburb than the inner suburb.
 - (D) The number of letters posted in the inner-city suburb had a smaller range.
16. The 'time and a half' rate of pay for casual work in a salon is \$18.60 per hour.

What is the normal rate of pay per hour?

- (A) \$9.30
- (B) \$12.30
- (C) \$12.40
- (D) \$13.95

17. 12 green, 4 red, and 20 yellow marbles were placed in a bag.

1 green, 3 yellow and 2 red marbles were then randomly drawn from the bag and not replaced.

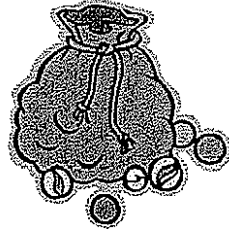

What is the probability that the next TWO marbles randomly selected from the bag will be the remaining red marbles?

- (A) $\frac{1}{29}$
- (B) $\frac{1}{15}$
- (C) $\frac{1}{435}$
- (D) $\frac{1}{2}$
18. An estimate of a person's maximum heart rate, R (in beats per minute) is given by the formula

$$R = 220 - A \quad \text{where } A \text{ is the person's age in years.}$$

It is estimated that a healthy person should have a target heart rate of 55% of their maximum rate when beginning to exercise.

Kristy is a healthy 17 years, 6 months old girl.

What is an estimate of her target heart rate, in beats per minute, when she begins exercising?

- (A) 202.5
- (B) 91.1
- (C) 210.4
- (D) 111.4

19. Office equipment originally purchased for \$8500 has a salvage value of \$500 after 5 year's use.

Using the straight line method, what annual rate did the equipment depreciate by?

- (A) 18.8%
- (B) 10.1%
- (C) 12.5%
- (D) 22.5%

20. The table below shows results for a group of men and women, who had their eyes tested at an eye clinic on a particular day.

	Passed eye test	Failed eye test
Men	240	
Women		45

In conducting the tests, it was found that 2 in every 5 men failed the eye test and 1 in every 5 women failed the test

Using the data from the table, how many men and women in total had their eyes tested during the day?

- (A) 320
 - (B) 340
 - (C) 580
 - (D) 625
21. A biologist determines that a termite is infesting a building site and reproducing at the rate of 12.5% every 25 days.

When first observed, it was estimated that 500 termites were present.

At this rate of reproduction, what would be an estimate of the number of termites on the site after 75 days?

- (A) 688
- (B) 712
- (C) 1300
- (D) 1688

22. A pattern of 5-point stars (each with edge length of 0.05 m), as shown below, forms a long banner on a wall.

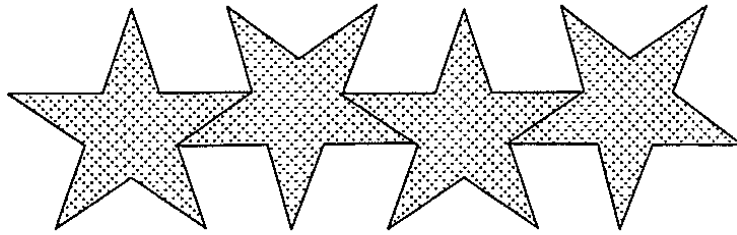

What is the perimeter of a banner containing 20 stars?

- (A) 1.62 m
- (B) 8 m
- (C) 8.1 m
- (D) 9 m

Section II

78 marks

Attempt Questions 23 – 28

Allow about 2 hours for this section

Answer each question in a SEPARATE writing booklet. Extra writing booklets are available.

All necessary working should be shown in every question.

Question 23 (13 marks) Use a SEPARATE writing booklet

Marks

- (a) Competition rules ensure that soccer balls have a weight within certain limits.

A number of balls were weighed and the results, which satisfied a normal distribution, were recorded on the bell curve shown below.

Weight of competition soccer balls

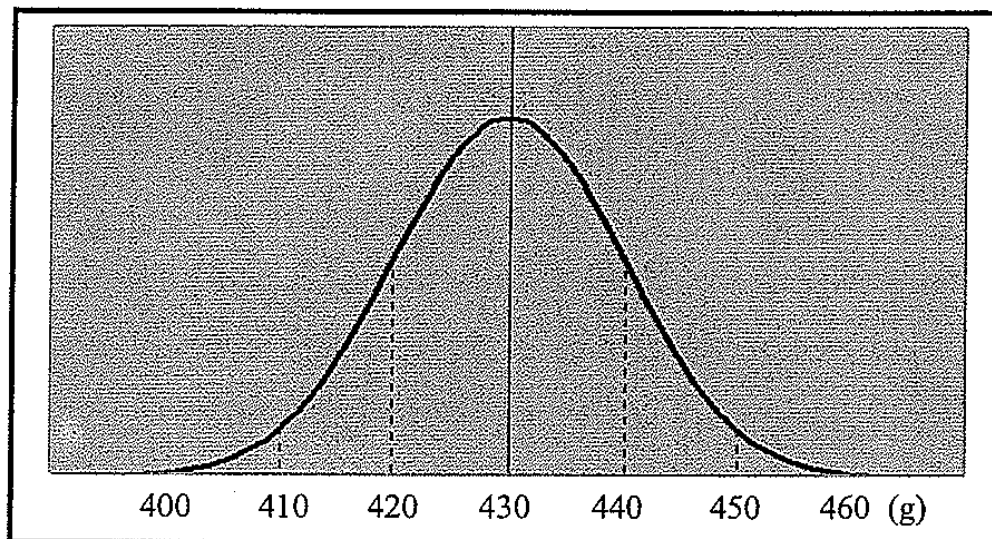

Use the information on the diagram above to answer the following questions.

- (i) What was the mean weight of soccer balls tested? 1
- (ii) What was the standard deviation? 1
- (iii) What z-score corresponds to a weight of 410 g? 1

Question 23 continues

- (iv) Competition rules require that the weights of the balls are between 410g and 450g.
- What percentage of the balls tested would satisfy these requirements? **1**
- (v) What is the probability that, if a ball was randomly selected from those tested, it would weigh more than 450g? **1**
- (b) The probability that it will rain on any day at a tropical resort is 0.8. Using a probability tree diagram or otherwise:
- (i) What is the probability that it will rain on two consecutive days at the resort? **1**
- (ii) What is the probability that it will rain on only one of two consecutive days? **2**
- (iii) What is the probability that it will rain on any given weekend? **2**
- (c) Researchers have found a new test for a virus. They have tested it on a group of patients for whom it is already known whether they have the virus.

	Positive test result	Negative test result	Total
Patients with virus	48	12	60
Patients without virus	72	1068	1140
Total	120	1080	1200

- (i) What percentage of patients had the virus? **1**
- (ii) What is the probability that a patient with the virus will be correctly identified by this test? **1**
- (iii) How many of the tests gave the wrong result? **1**

End of Question 23

Question 24 (13 marks) Use a SEPARATE writing booklet

Marks

- (a) The lamp on the desk below is 90cm from the book and stands 25cm vertically.

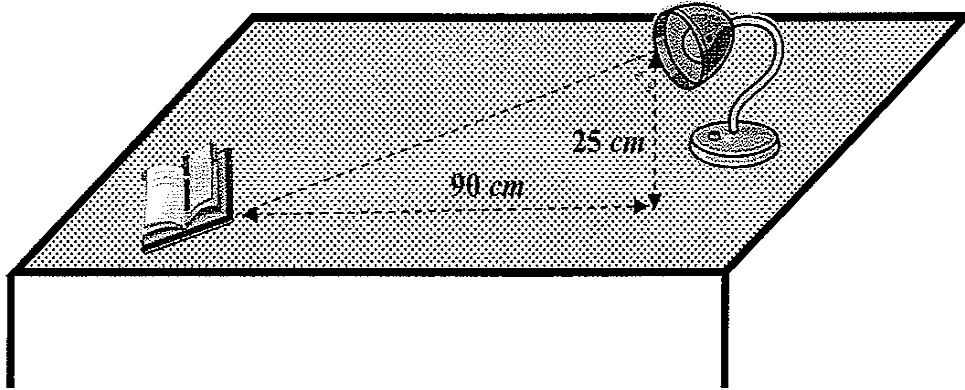

- (i) Calculate the angle of elevation (to the nearest degree) of the light from the book. 2
- (ii) Determine the length (L) of the light beam (to one decimal place) 2
- (iii) The intensity (I) of the light beam (measured in watts) is given by the formula
- $$I = \frac{523500}{L^2}$$
- Use this formula to determine the intensity of the beam at the book. 2
- (iv) When the lamp is moved closer to the book, the new angle of elevation is 20° .
- How far (correct to one decimal place) was the lamp moved toward the book? 2

Question 24 continues

- (b) At the end of every six months Marie invests \$1250 into a retirement fund. which pays interest at 7% p.a. with interest compounded six monthly.
- (i) Convert the annual interest rate to a six monthly rate expressed as a decimal. **1**

 - (ii) How much (to the nearest \$) will Marie have in her fund at the end of 20 years? **3**

 - (iii) How much interest was earned on the investment over the 20 years? **1**

End of Question 24

Question 25 (13 marks) Use a SEPARATE writing booklet

Marks

- (a) The diagram below shows the cross-section of a creek, with depths perpendicular to the creek bed shown in metres, at horizontal intervals of 4 metres.

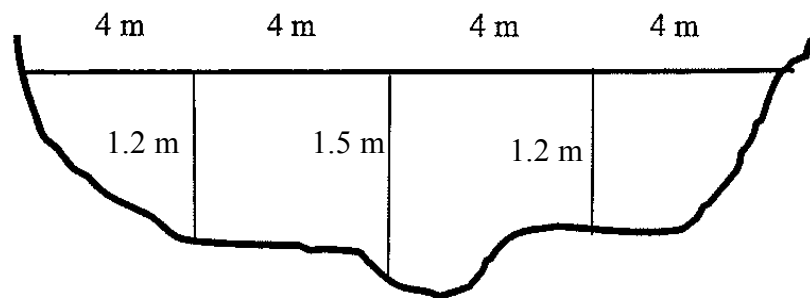

- (i) Use Simpson's rule, with two applications, to calculate the approximate area of this cross-section. 2
- (ii) Water flows through this section of the creek at a speed of 40 cm/s.
Convert this speed to metres/hour. 1
- (iii) Calculate the approximate volume of water in litres that flows past this section in one hour. 2
- Use the conversion $1 \text{ m}^3 = 1000 \text{ L}$
- (b) The stopping distance of a car is proportional to the square of the car's speed. A car travelling at 50 km/h has a stopping distance of 30 m. If the stopping distance is 18 m what is the car's speed? 2

Question 25 continues

- (c) Leanne and William are considering taking out a home loan of \$350 000. The interest rate is 6.0% p.a., compounding monthly. The length of the loan is 25 years.

(i) Using the formula $M = N \left(\frac{r(1+r)^n}{(1+r)^n - 1} \right)$

where M is the amount of each repayment

N is the amount borrowed

r is the interest rate per repayment period

n is the number of repayments to be made

Find the monthly repayment.

2

- (ii) Find the total amount to be repaid.

1

- (iii) Find the total interest paid on the loan.

1

- (iv) Both Leanne and William agree that they will take out the loan if repayments are no more than 25% of their gross salary. Their combined gross salary is \$102 000.

Should they take out the loan? Justify your answer with suitable calculations.

2

End of Question 25

Question 26 (13 marks) Use a SEPARATE writing booklet

Marks

- (a) A business replaces its computer system with a new system. The cost of the new system is \$375 000.

The system was installed in January, 2007 and then depreciated at 32% of its value each year.

- (i) What was the depreciated value of the system in January, 2008 2
- (ii) What will the system's value be in January, 2009? 1
- (iii) In what year will its depreciated value be \$8000? (You may use trial and error.) 2

- (b) The diagram below shows one section of a factory production line that fills cylindrical cans with soup from a mixer.

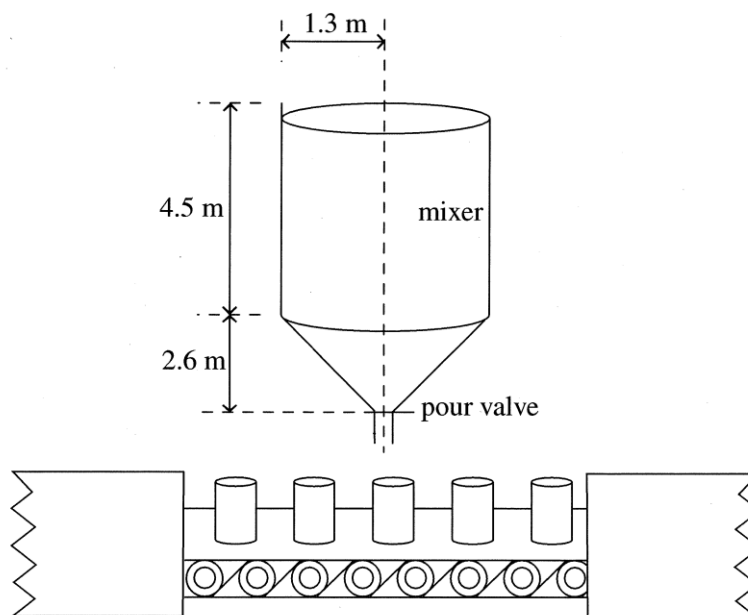

- (i) The mixer is in the shape of a cylinder on top of an inverted cone.

Show that the volume of the mixer is 28.5 m^3 to one decimal place.

2

Question 26 continues

(ii) Calculate the capacity of the mixer in litres. **1**

(iii) The capacity of a small soup can is 375 mL.

How many small cans of soup can be filled with the contents of the mixer ? **1**

(c) Louisa's gym trainer told her to exercise at a level that would make her heart rate 23 beats in 10 seconds. The trainer explained that 23 beats in 10 seconds represents 70% of Louisa's maximum heart rate.

Determine Louisa's maximum heart rate in beats per minute. Express your answer correct to the nearest whole beat. **2**

(d) The formula $C = \sqrt{kRT}$ gives the speed of sound in gases.

Make T the subject of the formula. **2**

End of Question 26

Question 27 (13 marks) Use a SEPARATE writing booklet

Marks

- (a) Members at Louisa's gym are measured each month and the number of kilograms and centimetres of excess fat they have lost are recorded. This scatter graph shows the results of females who have been gym members for 2 months.

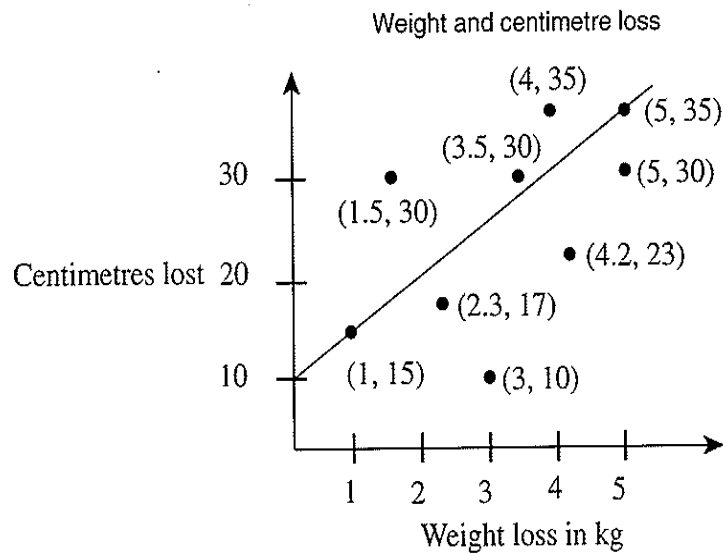

A line of fit is shown on the graph.

- (i) Use two of the four terms **strong**, **weak**, **positive** and **negative** to describe the correlation displayed on the scatter graph. 2
- (ii) What is the gradient of the line of fit? 1
- (iii) Determine the equation of the line of fit relating centimetres lost (C) and weight loss (W) 1
- (iv) Louisa lost 10 kg during her first two months at the gym.

Use the equation of the line of fit to predict the number of centimetres Louisa lost. 1

Question 27 continues

- (b) Jasmine has borrowed \$150 000 at an interest rate of 0.8% per month, interest compounded monthly.

The repayments have been set at \$1800 per month.

The loan balance sheet below shows the interest charged and the balance owing for the first month of the loan.

Month	Principal (At the start of the month)	Monthly Interest Charged	Monthly Payment	Balance (Owing at the end of the month)
1	\$150 000	\$1200	\$1800	X
2		Y	\$1800	Z

Calculate the value of X, Y and Z in the table.

3

- (c) The table below shows the monthly repayments for each \$1000 borrowed, for two different types of loans.

Type of Loan	Period of Loan				
	5 Years	10 years	15 years	20 years	25 years
Eastbank Loan	\$19.33	\$11.10	\$8.44	\$7.20	\$6.44
First Home Loan	\$19.80	\$11.61	\$9.00	\$7.75	\$7.07

To purchase her house, Jane borrows \$140 000 by taking out a First Home Loan, to be repaid over 10 years.

- (i) Use the table above to find Jane's monthly repayment. 1
- (ii) Find the total amount that Jane will repay over 10 years. 1
- (iii) How much interest will Jane repay on this loan? 1
- (iv) Peter can afford to pay \$850 per month for an Eastbank loan over 20 years. What is the maximum amount Peter can borrow? Give your answer to the nearest \$100. 2

End of Question 27

Question 28 (13 marks) Use a SEPARATE writing booklet

Marks

(a) A radial survey of a tract of land $PQRS$ is shown in the following diagram

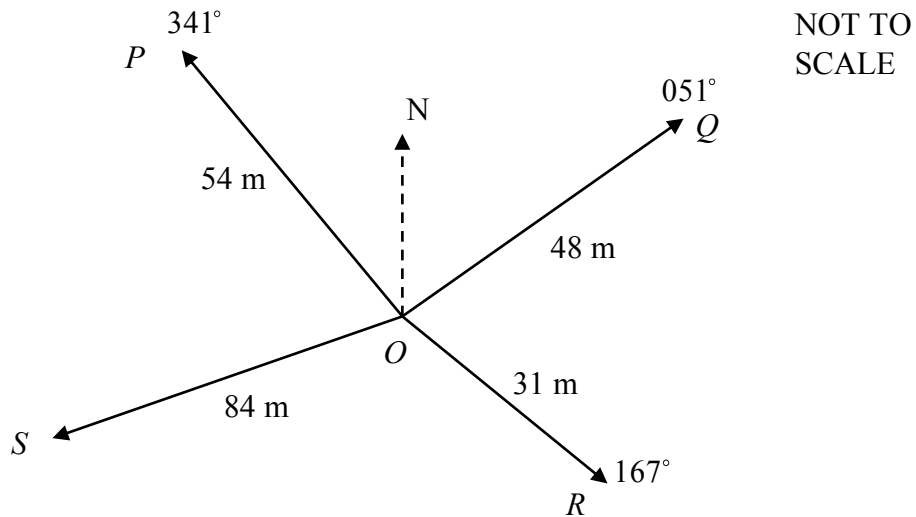

- (i) What is the size of $\angle POQ$? 1

- (ii) Find the area of $\triangle POQ$ (to nearest square metre). 2

- (iii) If the distance from R to S is 92 m, calculate $\angle ROS$, correct to the nearest degree. 2

- (iv) Hence, or otherwise, find the bearing of S from O . 1

Question 28 continues

- (b) The box-and-whisker plot shown below compares the marks of students in two classes.

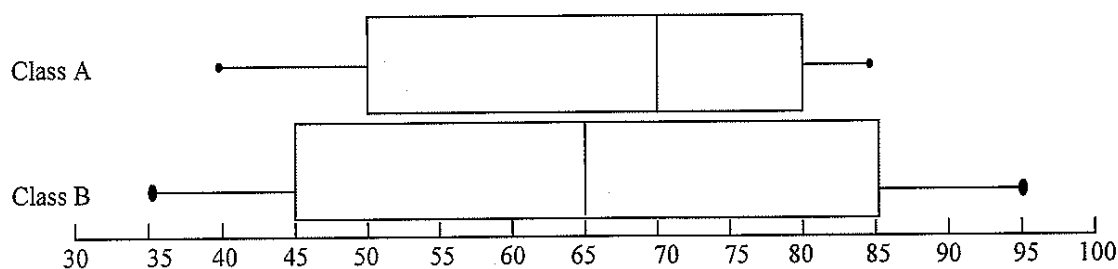

- (i) What is the interquartile range of class B ? 1
- (ii) If 8 students received a mark of 80 or more in class A how many people are in the class ? 1
- (c) A group of six people consists of Kate, Stuart, Sarah, Margot, Peter and Anna.
- (i) How many ways can they be arranged in a line? 1
- (ii) From this group of six, three people are chosen to help in the tuckshop.
How many different groups of three can be chosen? 1
- (iii) What is the probability that Stuart, Sarah, and Margot are chosen to help in the tuckshop? 1

Question 28 continues

- (d) A car was test driven at various speeds and the petrol consumption was recorded. The results are shown in the following graph.

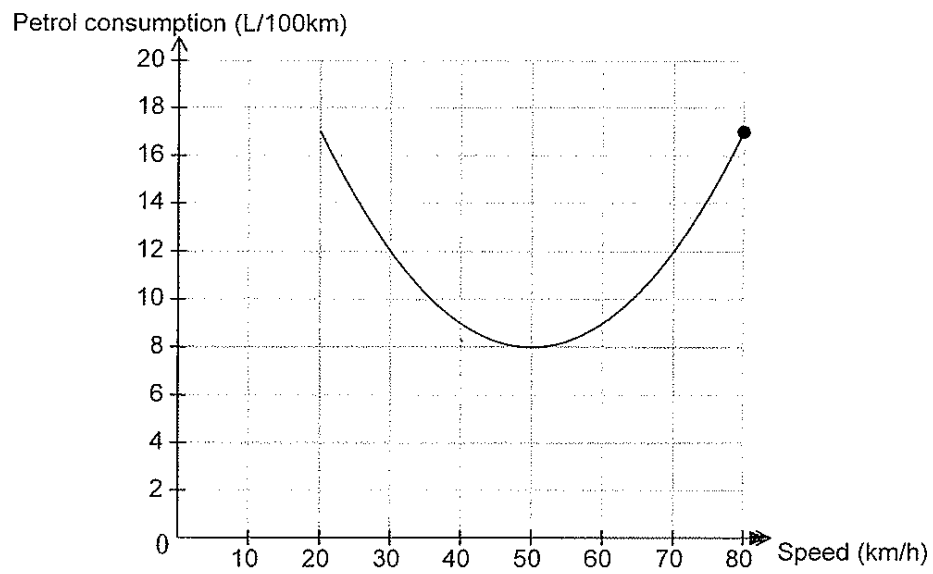

During the test, the car was driven at 70 km/h for 50 km. How much petrol did it consume?

2

End of Exam

General Mathematics

Set:

Section I Multiple-Choice Answer Sheet

- 1 A ○ B ○ C ○ D ○
- 2 A ○ B ○ C ○ D ○
- 3 A ○ B ○ C ○ D ○
- 4 A ○ B ○ C ○ D ○
- 5 A ○ B ○ C ○ D ○
- 6 A ○ B ○ C ○ D ○
- 7 A ○ B ○ C ○ D ○
- 8 A ○ B ○ C ○ D ○
- 9 A ○ B ○ C ○ D ○
- 10 A ○ B ○ C ○ D ○
- 11 A ○ B ○ C ○ D ○
- 12 A ○ B ○ C ○ D ○
- 13 A ○ B ○ C ○ D ○
- 14 A ○ B ○ C ○ D ○
- 15 A ○ B ○ C ○ D ○
- 16 A ○ B ○ C ○ D ○
- 17 A ○ B ○ C ○ D ○
- 18 A ○ B ○ C ○ D ○
- 19 A ○ B ○ C ○ D ○
- 20 A ○ B ○ C ○ D ○
- 21 A ○ B ○ C ○ D ○
- 22 A ○ B ○ C ○ D ○

FORMULAE SHEET

Area of an annulus

$$A = \pi(R^2 - r^2)$$

R = radius of outer circle

r = radius of inner circle

Area of an ellipse

$$A = \pi ab$$

a = length of semi-major axis

b = length of semi-minor axis

Area of a sector

$$A = \frac{\theta}{360} \pi r^2$$

θ = number of degrees in central angle

Arc length of a circle

$$l = \frac{\theta}{360} 2\pi r$$

θ = number of degrees in central angle

Simpson's rule for area approximation

$$A \approx \frac{h}{3} (d_f + 4d_m + d_l)$$

h = distance between successive measurements

d_f = first measurement

d_m = middle measurement

d_l = last measurement

Surface area

Sphere $A = 4\pi r^2$

Closed cylinder $A = 2\pi rh + 2\pi r^2$

r = radius

h = perpendicular height

Volume

Cone $V = \frac{1}{3} \pi r^2 h$

Cylinder $V = \pi r^2 h$

Pyramid $V = \frac{1}{3} Ah$

Sphere $V = \frac{4}{3} \pi r^3$

r = radius

h = perpendicular height

A = area of base

Sine rule

$$\frac{a}{\sin A} = \frac{b}{\sin B} = \frac{c}{\sin C}$$

Area of a triangle

$$A = \frac{1}{2} ab \sin C$$

Cosine rule

$$c^2 = a^2 + b^2 - 2ab \cos C$$

or

$$\cos C = \frac{a^2 + b^2 - c^2}{2ab}$$

FORMULAE SHEET

Simple interest

$$I = Prn$$

P = initial quantity

r = percentage interest rate per period, expressed as a decimal

n = number of periods

Compound interest

$$A = P(1+r)^n$$

A = final balance

P = initial quantity

n = number of compounding periods

r = percentage interest rate per compounding period, expressed as a decimal

Future value (A) of an annuity

$$A = M \left\{ \frac{(1+r)^n - 1}{r} \right\}$$

M = contribution per period, paid at the end of the period

Present value (N) of an annuity

$$N = M \left\{ \frac{(1+r)^n - 1}{r(1+r)^n} \right\}$$

or

$$N = \frac{A}{(1+r)^n}$$

Straight-line formula for depreciation

$$S = V_0 - Dn$$

S = salvage value of asset after n periods

V_0 = purchase price of the asset

D = amount of depreciation apportioned per period

n = number of periods

Declining balance formula for depreciation

$$S = V_0(1-r)^n$$

S = salvage value of asset after n periods

r = percentage interest rate per period, expressed as a decimal

Mean of a sample

$$\bar{x} = \frac{\sum x}{n}$$

$$\bar{x} = \frac{\sum fx}{\sum f}$$

\bar{x} = mean

x = individual score

n = number of scores

f = frequency

Formula for a z-score

$$z = \frac{x - \bar{x}}{s}$$

s = standard deviation

Gradient of a straight line

$$m = \frac{\text{vertical change in position}}{\text{horizontal change in position}}$$

Gradient–intercept form of a straight line

$$y = mx + b$$

m = gradient

b = y-intercept

Probability of an event

The probability of an event where outcomes are equally likely is given by:

$$P(\text{event}) = \frac{\text{number of favourable outcomes}}{\text{total number of outcomes}}$$

GENERAL

SECTION I

1. C
2. B
3. B
4. A
5. A
6. C
7. C
8. B
9. D
10. B
11. C
12. B
13. C
14. C
15. B
16. C
17. C
18. D
19. A
20. D
21. B
22. C

SECTION II

- 23.
- (a) (i) 430
- (ii) 10
- (iii) $-\frac{20}{10} = -2$
- (iv) 95%
- (v) 0.025
- b. (i) $0.8 \times 0.8 = 0.64$
- (ii) $0.8 \times 0.2 \times 2 = 0.32$
- (iii) $0.64 + 0.32 = 0.96$
- c. (i) $\frac{60}{1200} \times 100 = 5\%$
- (ii) $\frac{48}{60} \times 100 = 80\%$
- (iii) $72 + 12 = 84$

- 24.
- (a) (i) $\tan \theta = \frac{25}{90}$
 $\theta = 16^\circ$
- (ii) $\sin 16^\circ = \frac{25}{L}$ OR $L^2 = 8725$
 $L = \frac{25}{\sin 16^\circ}$
 $= 90.7 \text{ cm}$
 $L = 93.4 \text{ cm}$
- (iii) $I = \frac{523500}{90.7^2}$ OR $I = \frac{523500}{93.4^2}$
 $= 63.7 \text{ W} = 60 \text{ W}$
- (iv) $\tan 20^\circ = \frac{25}{x}$
 $x = \frac{25}{\tan 20^\circ}$
 $= 68.7$
 Distance = $90 - 68.7 = 21.3 \text{ cm}$
- (b) (i) 0.035
- (ii) $A = 1250 \left[\frac{(1.035)^{40} - 1}{0.035} \right] = \105688
- (iii) $I = 105688 - (40 \times 1250) = \55688

SECTION 2

25.

(a) (i) $A = \frac{4}{3}(0 + 1.5 + 4 \times 1.2) + \frac{4}{3}(1.5 + 0 + 4 \times 1.2)$
 $= 16.8 \text{ m}^2$

(ii) $\frac{40 \times 60 \times 60}{100}$
 $= 1440 \text{ m}^2$

(iii) 16.8×1440
 $= 24192000 \text{ L}$

(b) $D = h s^2$

$30 = h \times 50^2$

$h = 0.012$

$18 = 0.012 s^2$

$s = 38.7 \text{ km/h}$

(c) (i) $M = 350000 \left[\frac{0.005(1.005)^{300}}{(1.005)^{300} - 1} \right]$
 $= \$225505$

(ii) 225505×300
 $= \$676515$

(iii) $\$676515 - \350000
 $= \$326515$

(iv) $25\% \text{ gross} = \frac{0.25 \times 102000}{12}$
 $= \$2125$

No, Monthly instalment too big.

26.

(a) (i) $\$375000 \times 0.68$
 $= \$255000$

(ii) $\$255000 \times 0.68$
 $= \$173400$

(iii) Try different values of n

$375000(0.68)^9$

$= \$11658$

$375000(0.68)^{10}$

$= \$7927$

\therefore After 10 years

(i) $V = \pi \times 1.3^2 \times 4.5$
 $+ \frac{1}{3} \times \pi \times 1.3^2 \times 2.6$

$= 28.5 \text{ m}^3$

(ii) $1000 \times 28.5 = 28500 \text{ L}$

(iii) $28500 \div 0.375$
 $= 76000$

(c) $70\% = 23 \times 6 = 138$

MHR $= \frac{138}{70} \times 100 = 197$

(d) $C^2 = kRT$
 $T = \frac{C^2}{kR}$

27.

(a) (i) positive, weak

(i) $\frac{35-15}{5-1} = 5$

(ii) $C = 5W + 10$

(iii) $C = 5 \times 10 + 10$
 $= 60 \text{ cm}$

(b) $X = 150000 + 1200 - 1800$
 $= \$149400$

$Y = 149400 \times 0.008$
 $= \$1195.20$

$Z = 149400 + 1195.20$
 $- 1800$

$= \$148795.20$

(c) (i) 11.61×140
 $= \$1625.40$

(ii) $\$1625.40 \times 12 \times 10$
 $= \$195048$

(iii) $\$195048 - 140000$
 $= \$55048$

(iv) $850 \div 7.20 \times 1000$
 $= \$118100$

28.

(a) (i) $19^\circ + 51^\circ = 70^\circ$

(ii) $A = \frac{1}{2} \times 54 \times 48 \times \sin 70^\circ$
 $= 1218 \text{ m}^2$

(iii) $\cos \angle ROS = \frac{84^2 + 31^2 - 92^2}{2 \times 84 \times 31}$

$\cos \angle ROS = -0.885$

$\angle ROS = 95^\circ$

(iv) $167 + 95$
 $= 262^\circ$

(b) (i) $85 - 45 = 40$

(ii) $\frac{1}{4} \text{ scores} = 8$

no. in class = 32

(c) (i) $6 \times 5 \times 4 + 3 \times 2 \times 1 = 720$

(ii) $\frac{6 \times 5 \times 4}{3 \times 2 \times 1} = 20$

(iii) $\frac{1}{20}$

(d) $12 \text{ L} - \text{from graph}$

$12 \div 2 = 6 \text{ L}$