



2008

**TRIAL HIGHER SCHOOL CERTIFICATE
EXAMINATION**

Mathematics

General Instructions

- Reading Time – 5 minutes
- Working Time – 3 hours
- Write using black or blue pen
- Board approved calculators may be used
- A table of standard integrals is provided at the back of this paper
- All necessary working should be shown in every question

Total Marks – 120

- Attempt Questions 1 – 10
- All questions are of equal value

BLANK PAGE

Total Marks – 120**Attempt Questions 1 – 10****All questions are of equal value**Begin each question in a SEPARATE writing booklet. Extra booklets are available.

	Marks
Question 1 (12 marks) Use a SEPARATE writing booklet.	
a) Evaluate $\left(\frac{1}{e^{2.5}} - 1\right)^2$ correct to 3 significant figures.	2
b) Solve $ 2x-1 \leq 3$	2
c) If $\frac{4}{2-\sqrt{3}} = a + b\sqrt{3}$ find the values of a and b .	2
d) Find the tenth term of the arithmetic series $4\frac{1}{2} + 3 + 1\frac{1}{2} + \dots$	2
e) Factorise $2x^2 + 7x - 4$	2
f) Find the perpendicular distance from the point $(1, 3)$ to the line $6x - 8y + 5 = 0$	2

End of Question 1

Question 2 (12 marks) Use a SEPARATE writing booklet.

Marks

a) Differentiate with respect to x

(i) $x \sin x$

2

(ii) $(1 + e^x)^5$

2

b) (i) Find $\int \sec^2 3x \, dx$

2

(ii) Evaluate $\int_0^3 \frac{6x}{1+x^2} \, dx$

3

c) Find the equation of the tangent to the curve $y = \cos 3x$ at the point whose x -coordinate is $\frac{\pi}{6}$.

3

End of Question 2

Question 3 (12 marks) Use a SEPARATE writing booklet.

Marks

a)

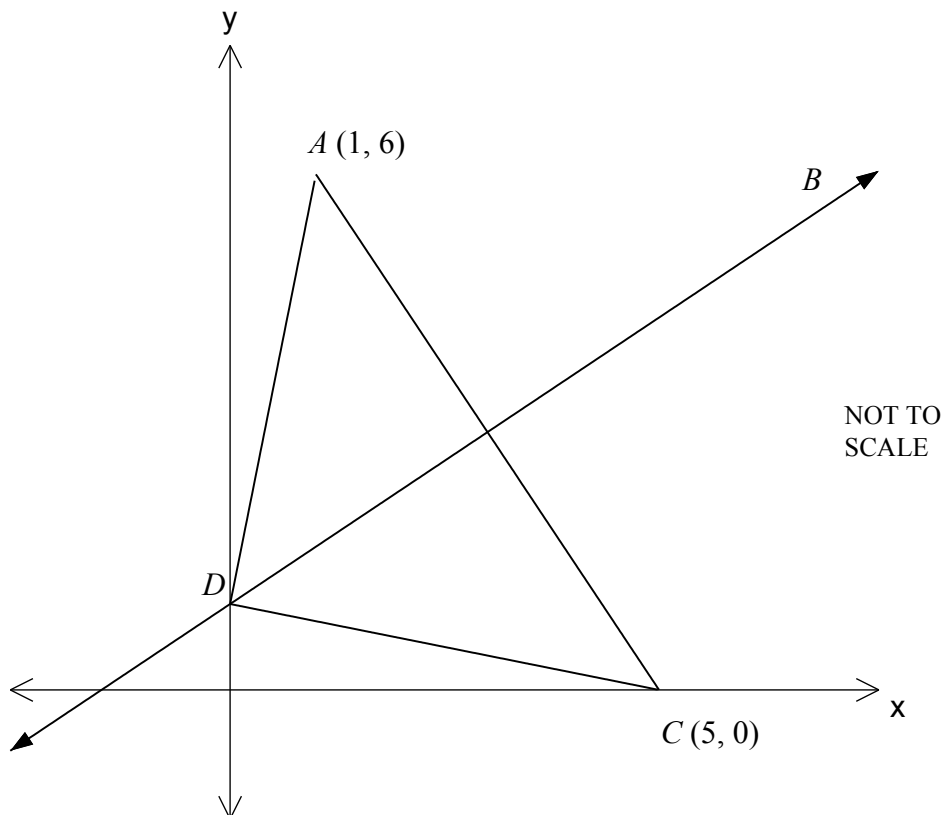

The points A and C have coordinates $(1, 6)$ and $(5, 0)$ respectively.
The line BD has an equation of $2x - 3y + 3 = 0$ and meets the y axis in D .

- | | | |
|------|--|---|
| i) | The point M is the midpoint of AC . Show that M has coordinates $(3, 3)$. | 1 |
| ii) | Show that M lies on BD . | 1 |
| iii) | Find the gradient of the line AC . | 1 |
| iv) | Show that BD is perpendicular to AC . | 2 |
| v) | Find the distance AC . | 1 |
| vi) | Explain why the quadrilateral $ABCD$ is a kite regardless of the position of B . | 1 |

Question 3 continues on next page.

Question 3 continued**Marks**

- b) Michael is training for a local marathon. He has trained by completing practice runs over the marathon course. So far he has completed three practice runs with times shown below.

Week 1	Week 2	Week 3
3 hours	2 hours 51 minutes	2 hours 42 minutes 27 seconds

- i) Show that these times form a geometric series with a common ratio $r = 0.95$. **1**
- ii) If this series continues, what would be his expected time in Week 5, to the nearest second? **1**
- iii) How many hours, minutes and seconds (to the nearest second) will he have run, in total, in his practice runs in these 5 weeks? **1**
- iv) If the previous winning time for the marathon was 2 hours and 6 minutes, how many weeks must he keep practicing to be able to run the marathon in less than the previous winning time? **2**

End of Question 3

Question 4 (12 marks) Use a SEPARATE writing booklet.

Marks

a) Show that:

2

$$\sqrt{\frac{\operatorname{cosec}^2 x - \cot^2 x - \cos^2 x}{\cos^2 x}} = \tan x$$

b) For the function $y = x^3 - 3x^2 - 9x + 1$, find the values of x for which the curve is decreasing.

3

c)

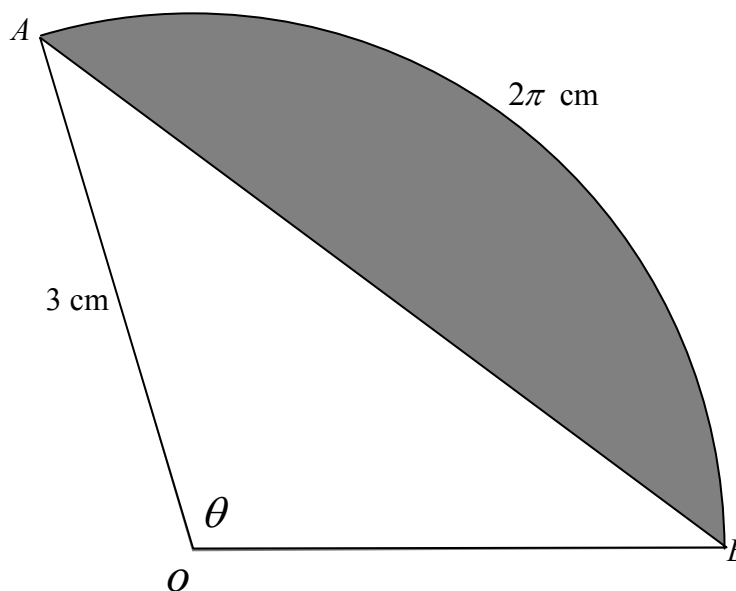

NOT TO
SCALE

AOB is a sector of a circle, centre O and radius 3 cm .

The length of arc AB is $2\pi \text{ cm}$. AB is a chord.

(i) Calculate the angle θ subtended at the centre of the circle by the arc AB .

1

(ii) Calculate the exact area of the shaded segment.

2

Question 4 continues on next page.

Question 4 continued

- d) Peta and Quentin are pilots of two light planes which leave Resthaven station at the same time. Peta flies on a bearing of 330° at a speed of 180 km/h and Quentin flies on a bearing of 080° at a speed of 240 km/h. Copy the diagram below onto your answer page and mark the information on the diagram.

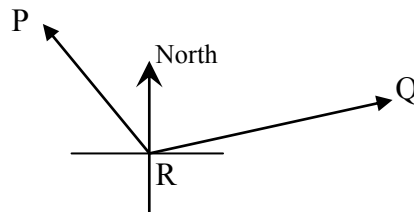

- i) Show that Peta and Quentin are 692 km (to the nearest km) apart after 2 hours? **2**
- ii) What is the bearing of Quentin from Peta after 2 hours. (Answer to the nearest degree.) **2**

End of Question 4

Question 5 (12 marks) Use a SEPARATE writing booklet.

Marks

- a) In the diagram below $AE = ED = AD = DC$, $\angle ADC = 90^\circ$ and $AE \parallel BC$.
 $\angle BAC = 51^\circ$

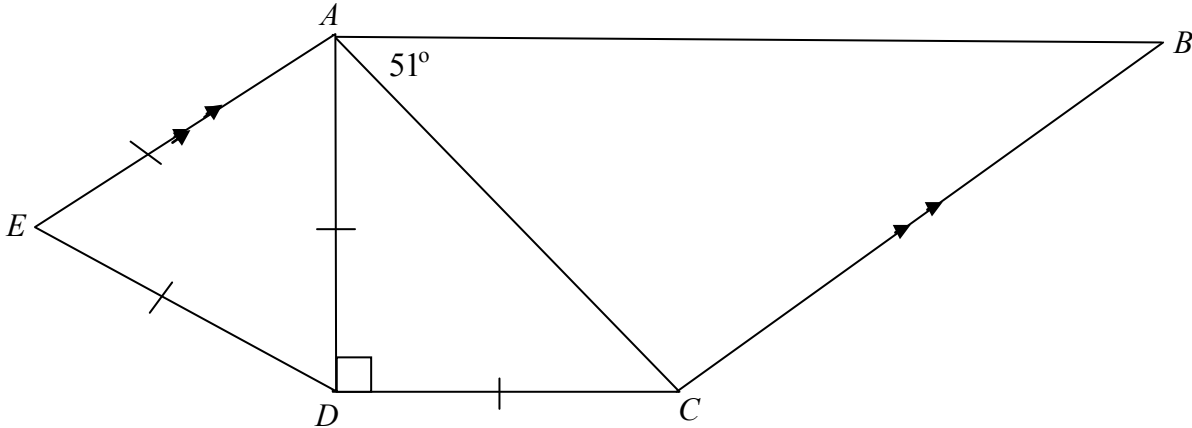

- i) Find the size of $\angle EAB$. Give reasons for your answer. 3
- ii) Find the size of $\angle ABC$. Give reasons for your answer. 1
- b) A particle moves in a straight line so that its displacement, in metres, is given by
- $$x = \frac{4t^2 + t + 8}{4t + 1} \text{ where } t \text{ is measured in seconds.}$$
- i) Find the initial displacement of the particle. 1
- ii) Find an expression for the velocity of the particle. 1
- iii) Show that the particle is stationary when $t = \frac{-1 + 4\sqrt{2}}{4}$ seconds (or 1.2 seconds to one decimal place). 2
- iv) Find the total distance travelled in the first two seconds. (Answer to 1 decimal place.) 2
- c) Solve the pair of simultaneous equations 2

$$3x - y = 10$$

$$x = y + 2$$

End of Question 5

Question 6 (12 marks) Use a SEPARATE writing booklet.

Marks

- a) For the function $y = x^6 - 6x^4$
- i) Find the x coordinates of the points where the curve crosses the axes. **2**
 - ii) Find the coordinates of the stationary points and determine their nature. **4**
 - iii) Find the coordinates of any points of inflexion. **2**
 - iv) Sketch the graph of $y = x^6 - 6x^4$ indicating clearly the intercepts, stationary points and points of inflexion. **2**

- b) For a certain function $y = f(x)$, the sketch of $y = f'(x)$ is shown.

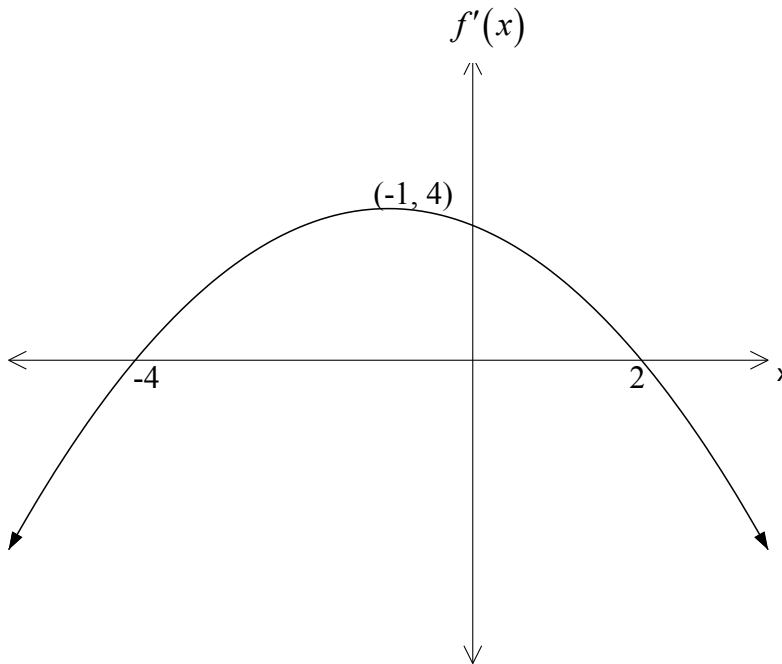

- Give the x coordinates of the stationary points on $y = f(x)$ and indicate if they are maxima or minima. **2**

End of Question 6

Question 7 (12 marks) Use a SEPARATE writing booklet.

Marks

a) Let $\log_a 2 = x$ and $\log_a 5 = y$. Find an expression, in terms of x and y , for

i) $\log_a 0.4$

1

ii) $\log_a 20$

2

b)

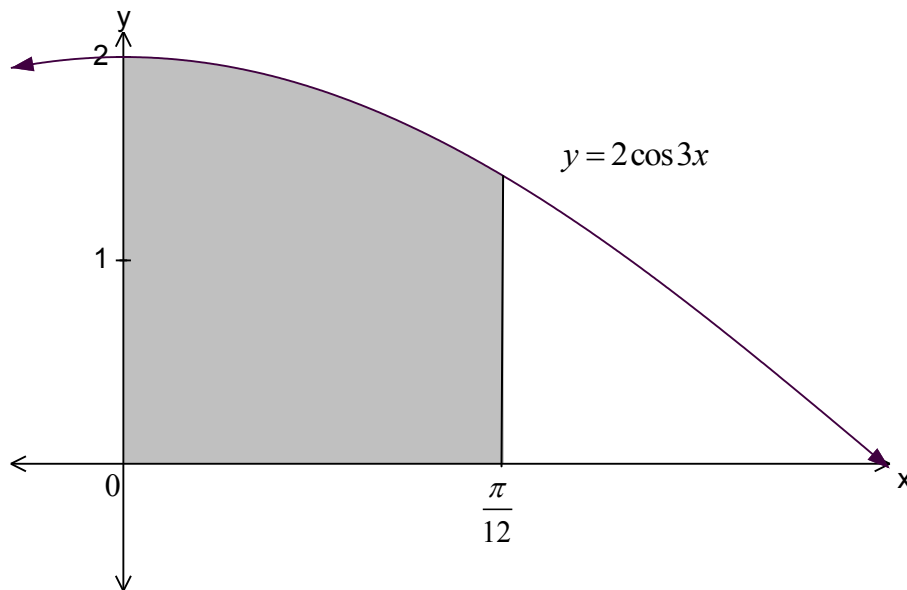

The diagram shows the graph of $y = 2 \cos 3x$.

3

Find the area enclosed by the curve $y = 2 \cos 3x$, the line $x = \frac{\pi}{12}$ and the x and y axes.

Question 7 continues on next page.

Question 7 continued

c)

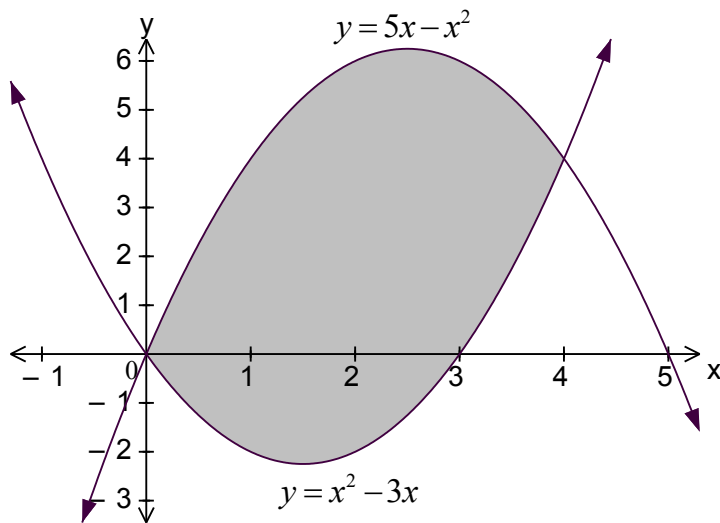

- i) Show that the curves $y = x^2 - 3x$ and $y = 5x - x^2$ intersect at the points $(0, 0)$ and $(4, 4)$. 2
- ii) Find the area enclosed between the two curves. 3
- d) Find $\frac{d}{dx} \log_e(\cos x)$. 1

End of Question 7

Question 8 (12 marks) Use a SEPARATE writing booklet.

Marks

- a) A city has a population which is growing at a rate that is proportional to the current population. The population at time t years is given by

$$P = Ae^{kt}$$

- i) Show that $P = Ae^{kt}$ satisfies the equation $\frac{dP}{dt} = kP$. 1
- ii) If the population at the start of 2006 when $t = 1$ was 147 200 and at the start of 2007 when $t = 2$ was 154 800, find the values of A and k . 2
- iii) Find the population at the start of 2009. 1
- iv) Find during which year the population will first exceed 200 000. 1

- b) In the diagram below, P is the midpoint of the side AB of the $\triangle ABC$. PQ is drawn parallel to BC .

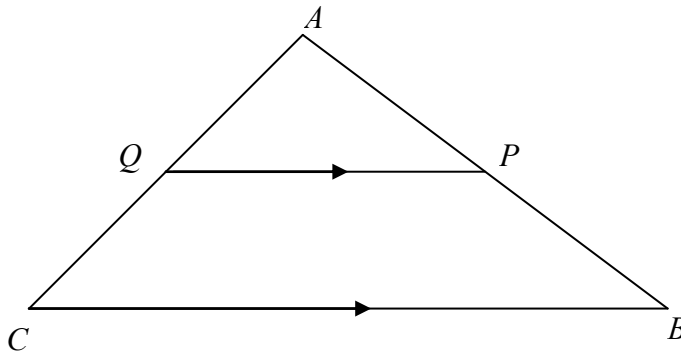

- i) Prove that $\triangle ABC \parallel \triangle APQ$. 2
- ii) Explain why Q is the midpoint of AC . 2
- c) Find an approximation for $\int_1^3 g(x) dx$ by using Simpson's Rule with the values in the table below. 2

x	1	1.5	2	2.5	3
$g(x)$	12	8	0	3	5

- d) Evaluate $\sum_{n=2}^5 (n^2 - 1)$ 1

End of Question 8

Question 9 (12 marks) Use a SEPARATE writing booklet.

Marks

- a) The diagram shows the region bounded by the curve $y = 2x^2 - 2$ the line $y = 6$ and the x and y axes.

3

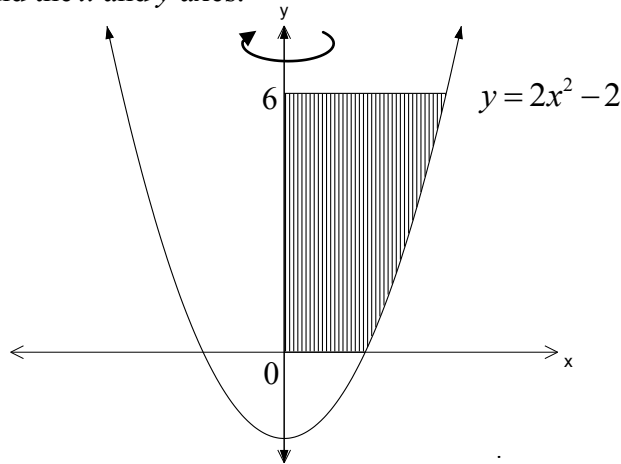

Find the volume of the solid of revolution formed when the region is rotated about the y axis.

- b) Sketch the function $y = \ln(x+1)$, showing its essential features.

2

- c) Given that $\frac{d}{dx}(e^{x^5}) = 5x^4 e^{x^5}$, find $\int 2x^4 e^{x^5} dx$.

1

- d) A car dealership has a car for sale for a cash price of \$20 000. It can also be bought on terms over three years. The first six months are interest free and after that interest is charged at the rate of 1% per month on that months balance. Repayments are to be made in equal monthly instalments beginning at the end of the first month.

A customer buys the car on these terms and agrees to monthly repayments of \$ M . Let \$ A_n be the amount owing at the end of the n th month.

- i) Find an expression for A_6 .
- ii) Show that $A_8 = \square(20\,000 - 6M)1.01^2 - M(1 + \square \square 1.01)$
- iii) Find an expression for A_{36} .
- iv) Find the value of M .

1

1

2

2

End of Question 9

Question 10 (12 marks) Use a SEPARATE writing booklet.

Marks

- a) A plant nursery has a watering system which repeatedly fills a storage tank then empties its contents to water different sections of the nursery. The volume of water (in cubic metres) in the tank at a time t is given by the equation

$$V = 2 - \sqrt{3} \cos t - \sin t \text{ where } t \text{ is measured in minutes.}$$

- i) Give an equation for $\frac{dV}{dt}$, the rate of change of the volume at a time t . **1**
- ii) Is the tank initially filling or emptying? **1**
- iii) At what time does the tank first become completely full and what is its capacity when full? **3**

Question 10 continues on next page.

Question 10 continued

Marks

- b) A truncated cone is to be used as a part of a hopper for a grain harvester. It has a total height of h metres. The top radius is to be t times greater than the bottom radius which is 2 metres.

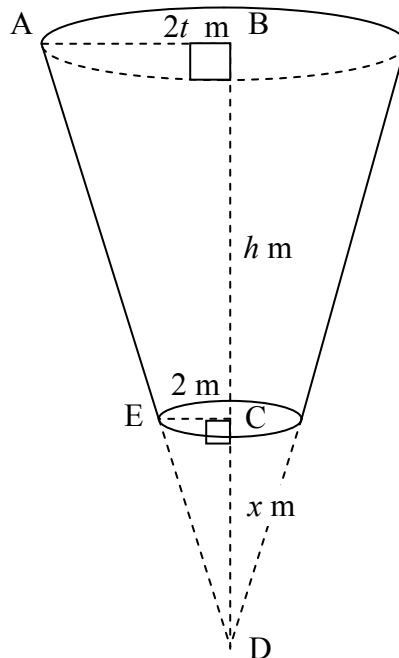

$$\begin{aligned} AB &= 2t \text{ metres} \\ BC &= h \text{ metres} \\ EC &= 2 \text{ metres} \\ CD &= x \text{ metres} \end{aligned}$$

- i) If x is the height of the removed section of the original cone, show using similar triangles that $x = \frac{h}{t-1}$ 2
- ii) Show that the volume of the truncated cone is given by 2

$$V = \left(\frac{4\pi h}{3} \right) (t^2 + t + 1)$$
- iii) If the upper radius plus the lower radius plus the height of the truncated cone must total 12 metres, calculate the maximum volume of the hopper. 3

End of Examination

STANDARD INTEGRALS

$$\int x^n dx = \frac{1}{n+1} x^{n+1}, \quad n \neq -1; \quad x \neq 0, \text{ if } n < 0$$

$$\int \frac{1}{x} dx = \ln x, \quad x > 0$$

$$\int e^{ax} dx = \frac{1}{a} e^{ax}, \quad a \neq 0$$

$$\int \cos ax dx = \frac{1}{a} \sin ax, \quad a \neq 0$$

$$\int \sin ax dx = -\frac{1}{a} \cos ax, \quad a \neq 0$$

$$\int \sec^2 ax dx = \frac{1}{a} \tan ax, \quad a \neq 0$$

$$\int \sec ax \tan ax dx = \frac{1}{a} \sec ax, \quad a \neq 0$$

$$\int \frac{1}{a^2 + x^2} dx = \frac{1}{a} \tan^{-1} \frac{x}{a}, \quad a \neq 0$$

$$\int \frac{1}{\sqrt{a^2 - x^2}} dx = \sin^{-1} \frac{x}{a}, \quad a > 0, \quad -a < x < a$$

$$\int \frac{1}{\sqrt{x^2 - a^2}} dx = \ln \left(x + \sqrt{x^2 - a^2} \right), \quad x > a > 0$$

$$\int \frac{1}{\sqrt{x^2 + a^2}} dx = \ln \left(x + \sqrt{x^2 + a^2} \right)$$

NOTE: $\ln x = \log_e x, \quad x > 0$

2008
TRIAL HSC
EXAMINATION

Mathematics

SOLUTIONS

Question 1		Trial HSC Examination- Mathematics
Part	Solution	Marks
(a)	$\left(\frac{1}{e^{2.5}} - 1\right)^2 = 0.84256 = 0.843$ (3 sig fig)	2
(b)	$ 2x - 1 \leq 3$ $-3 \leq 2x - 1 \leq 3$ $-2 \leq 2x \leq 4$ $-1 \leq x \leq 2$	2
(c)	$\frac{4}{2 - \sqrt{3}} = a + b\sqrt{3}$ $\frac{4}{2 - \sqrt{3}} = \frac{4}{2 - \sqrt{3}} \times \frac{2 + \sqrt{3}}{2 + \sqrt{3}}$ $= \frac{8 + 4\sqrt{3}}{4 - 3}$ $a + b\sqrt{3} = 8 + 4\sqrt{3}$ $a = 8$ and $b = 4$	2
(d)	$4\frac{1}{2} + 3 + 1\frac{1}{2} + \dots$ Series is arithmetic with $a = 4\frac{1}{2}$ and $d = -1\frac{1}{2}$ $T_n = a + (n - 1)d$ $T_{10} = 4.5 + 9 \times -1.5$ $T_{10} = -9$	2
(e)	$(x + 4)(2x - 1)$	2
(f)	$d = \frac{ 6(1) - 8(3) + 5 }{\sqrt{6^2 + (-8)^2}}$ $= \frac{ -13 }{\sqrt{100}}$ $= 1.3$ units	2

Question 2		Trial HSC Examination- Mathematics
Part	Solution	Marks
(a) i)	$x \cos x + \sin x$	2
ii)	$5(1 + e^x)^4 \times e^x$ $= 5e^x(1 + e^x)^4$	2
(b) i)	$\frac{1}{3} \tan 3x + c$	2

Question 2		Trial HSC Examination- Mathematics
Part	Solution	Marks
ii)	$\left[3 \ln(1+x^2) \right]_0^3$ $= 3[\ln 10 - \ln 1]$ $= 3 \ln 10$	3
(c)	$y' = -3 \sin 3x$ <p>when $x = \frac{\pi}{6}$, $y' = -3 \sin \frac{\pi}{2}$</p> $= -3$ <p>\therefore gradient of tangent is -3</p> <p>when $x = \frac{\pi}{6}$, $y = 0$.</p> <p>Equation of tangent is $3x + y - \frac{\pi}{2} = 0$</p>	3

Question 3		Trial HSC Examination- Mathematics
Part	Solution	Marks
(a)i)	<p>Midpoint of (1, 6) and (5, 0).</p> $MP = \left(\frac{1+5}{2}, \frac{6+0}{2} \right) = \left(\frac{6}{2}, \frac{6}{2} \right) = (3, 3)$	1
ii)	<p>Show that (3,3) lies on $2x - 3y + 3 = 0$</p> $LHS = 2(3) - 3(3) + 3$ $= 6 - 9 + 3$ $= 0 = RHS$ <p>So M lies on BD.</p>	1
iii)	<p>Gradient AC = $m_1 = \frac{6-0}{1-5} = \frac{6}{-4} = -\frac{3}{2}$</p>	1
iv)	<p>Find gradient m_2 of BD $2x - 3y + 3 = 0$</p> $2x - 3y + 3 = 0$ $3y = 2x + 3$ $y = \frac{2}{3}x + 1$ <p>$\therefore m_2 = \frac{2}{3}$</p> $m_1 \cdot m_2 = -\frac{3}{2} \cdot \frac{2}{3} = -1$ <p>\therefore BD is perpendicular to AC</p>	2

Question 3		Trial HSC Examination- Mathematics
Part	Solution	Marks
v)	$AC = \sqrt{(5-1)^2 + (0-6)^2}$ $= \sqrt{16+36}$ $= \sqrt{52}$ $= 2\sqrt{13} \text{ units}$	1
(vi)	<p>The lines AC and BD would form the diagonals of the quadrilateral ABCD. BD is the perpendicular bisector of AC from ii and iv above. The diagonals of a kite meet at right angles and one diagonal bisects the other, so ABCD meets the criteria for a kite.</p>	1
(b)i)	$\frac{2 \text{ hours } 51 \text{ minutes}}{3 \text{ hours}} = \frac{2.85}{3} = 0.95$ $\frac{2 \text{ hours } 42 \text{ minutes } 27 \text{ seconds}}{2 \text{ hours } 51 \text{ minutes}} = \frac{2.7075}{2.85} = 0.95$ <p>\therefore forms a geometric series with $r = 0.95$</p>	1
ii)	$a = 3, n = 5$ and $r = 0.95$ $u_5 = ar^{n-1}$ $= 3 \times 0.95^4$ $= 2.4435\dots$ $= 2 \text{ hours } 26 \text{ min } 37 \text{ s}$	1
iii)	$s_n = \frac{a(1-r^n)}{(1-r)}$ $= \frac{3(1-0.95^5)}{(1-0.95)}$ $= 13.573\dots$ $= 13 \text{ hours } 34 \text{ min } 23 \text{ s (to nearest s)}$	1
iv)	$u_n = ar^{n-1}$ $2 \text{ hours } 6 \text{ min} = 3 \times 0.95^{n-1}$ $3 \times 0.95^{n-1} = 2.1$ $0.95^{n-1} = 2.1 \div 3 = 0.7$ $\ln(0.95^{n-1}) = \ln(0.7)$ $(n-1)\ln(0.95) = \ln(0.7)$ $n-1 = \frac{\ln(0.7)}{\ln(0.95)}$ $n-1 = 6.953$ $n = 7.953\dots$ <p>Would need to continue for 8 weeks to better the time.</p>	2

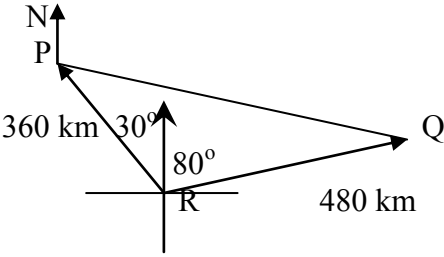
Question 4		Trial HSC Examination- Mathematics
Part	Solution	Marks
(a)	$\sqrt{\frac{\operatorname{cosec}^2 x - \cot^2 x - \cos^2 x}{\cos^2 x}} = \sqrt{\frac{1 - \cos^2 x}{\cos^2 x}}$ $= \sqrt{\frac{\sin^2 x}{\cos^2 x}}$ $= \frac{\sin x}{\cos x}$ $= \tan x$	2
(b)	$y' = 3x^2 - 6x - 9$ $x^2 - 2x - 3 < 0$ $(x+1)(x-3) < 0$ $\therefore \text{function is decreasing for } -1 < x < 3$	3
(c)i)	$l = r\theta$ $2\pi = 3\theta$ $\theta = \frac{2\pi}{3}$	1
(c)ii)	$A = \frac{1}{2}r^2(\theta - \sin\theta)$ $A = \frac{1}{2} \times 3^2 \left(\frac{2\pi}{3} - \sin \frac{2\pi}{3} \right)$ $A = \frac{9}{2} \left(\frac{2\pi}{3} - \frac{\sqrt{3}}{2} \right)$ $A = \frac{9}{2} \left(\frac{4\pi - 3\sqrt{3}}{6} \right) = \frac{3}{4} (4\pi - 3\sqrt{3}) \text{ units}^2$	2
(d)i)	 <p> $PQ^2 = 360^2 + 480^2 - 2 \times 360 \times 480 \cos 110^\circ$ $PQ^2 = 478202$ $PQ = 692 \text{ km (nearest km)}$ </p>	2

Question 4		Trial HSC Examination- Mathematics
Part	Solution	Marks
(d)ii	First find $\angle QPR$ $\frac{\sin \angle QPR}{480} = \frac{\sin 110^\circ}{692}$ $\sin \angle QPR = \frac{480 \times \sin 110^\circ}{692}$ $\sin \angle QPR = 0.652$ $\angle QPR = 41^\circ$ $\angle NPR = 150^\circ$ $\text{Bearing}(\angle NPQ) = 150^\circ - 41^\circ$ $= 109^\circ$ <div style="border: 1px solid black; padding: 5px; width: fit-content; margin: 10px auto;"> Can also be found using cos rule using the 3 sides.. </div>	2

Question 5		Trial HSC Examination- Mathematics
Part	Solution	Marks
(a)i	$\angle EAD = 60^\circ$ (equilateral $\triangle EAD$) $\angle DAC = 45^\circ$ (isosceles right-angled $\triangle DAC$) $\therefore \angle EAB = \angle EAD + \angle DAC + \angle CAB$ $= 60^\circ + 45^\circ + 51^\circ$ $= 156^\circ$	3
ii	$\angle ABC = 180^\circ - 156^\circ$ (superior \angle on \parallel lines, AE and BC) $= 24^\circ$	1
(b)i	$x = \frac{4t^2 + t + 8}{4t + 1}$ $x = \frac{4(0)^2 + (0) + 8}{4(0) + 1} \text{ when } t = 0$ $= 8$ \therefore initial displacement is 8 m	2
(b)ii	$x = \frac{4t^2 + t + 8}{4t + 1}$ $\therefore \frac{(4t + 1)(8t + 1) - (4t^2 + t + 8)(4)}{(4t + 1)^2}$ $= \frac{32t^2 + 12t + 1 - 16t^2 - 4t - 32}{(4t + 1)^2}$ $= \frac{16t^2 + 8t - 31}{(4t + 1)^2}$	1

Question 5		Trial HSC Examination- Mathematics
Part	Solution	Marks
(b)iii)	$\frac{16t^2 + 8t - 31}{(4t+1)^2} = 0$ $16t^2 + 8t - 31 = 0$ $t = \frac{-8 \pm \sqrt{8^2 - 4(16)(-31)}}{2(16)}$ $= \frac{-8 \pm \sqrt{2048}}{32}$ $= \frac{-8 \pm 32\sqrt{2}}{32}$ $= \frac{-1 \pm 4\sqrt{2}}{4}$ <p>So it is stationary when $t = \frac{-1 \pm 4\sqrt{2}}{4}$</p> <p>Only use positive value so $t = \frac{-1 + 4\sqrt{2}}{4} \approx 1.2 \text{ s (to one dec pl)}$</p>	2
(b)iv)	$t = \frac{-1 + 4\sqrt{2}}{4} \approx 1.2 \text{ s } v = 0, x \approx 2.58 \text{ (to 2 dec pl)}$ <p>When $t = 0$ $x = 8$ When $t = 2$ $x = 2.89$ (to 2 dec pl)</p> <p>Particle starts 8 units to the right of the origin, moving toward the origin, it stops after 1.2 sec at 2.58 m to right of origin, then begins to move away from the origin, being 2.89 units to the right of the origin after 2 sec.</p> <p>\therefore total distance travelled is $(8 - 2.58) + (2.89 - 2.58)$ $= 5.73 \text{ m}$ or 5.7 m (to 1 dec place)</p>	2
(c)	$3x - y = 10 \quad (1)$ $x = y + 2 \quad (2)$ $3(y + 2) - y = 10 \quad (3) \text{ sub (2) in (1)}$ $3y + 6 - y = 10$ $2y = 4$ $y = 2$ $x = (2) + 2 \quad \text{sub } y \text{ in (2)}$ $x = 4$ <p>solution (4, 2)</p>	2

Question 6		Trial HSC Examination- Mathematics
Part	Solution	Marks
(a)(i)	$y = x^6 - 6x^4$ Crosses axis where $x^6 - 6x^4 = 0$ $x^4(x^2 - 6) = 0$ $x^4(x - \sqrt{6})(x + \sqrt{6}) = 0$ Crosses axis where $x = 0$ and $x = \pm\sqrt{6}$	2
(a)(ii)	$y = x^6 - 6x^4$ $y' = 6x^5 - 24x^3$ $= 6x^3(x^2 - 4)$ $= 6x^3(x - 2)(x + 2)$ $y'' = 30x^4 - 72x^2$ Stationary points where $x = 0, y = 0, y'' = 0$ $x = 2, y = -32, y'' = 192$ $x = -2, y = -32, y'' = 192$ Stationary points $(-2, -32), (0, 0), (2, -32)$ $y'' = 30x^4 - 72x^2$ At $x = 0$ $y'' = 0$ so test either side At $x = 1$ $y'' = -42 \therefore$ concave down. At $x = -1$ $y'' = -42 \therefore$ concave down \therefore maximum at $(0, 0)$ At $x = 2$ $y'' = 192 \therefore$ minimum at $(2, -32)$. At $x = -2$ $y'' = 192 \therefore$ minimum at $(-2, -32)$.	4

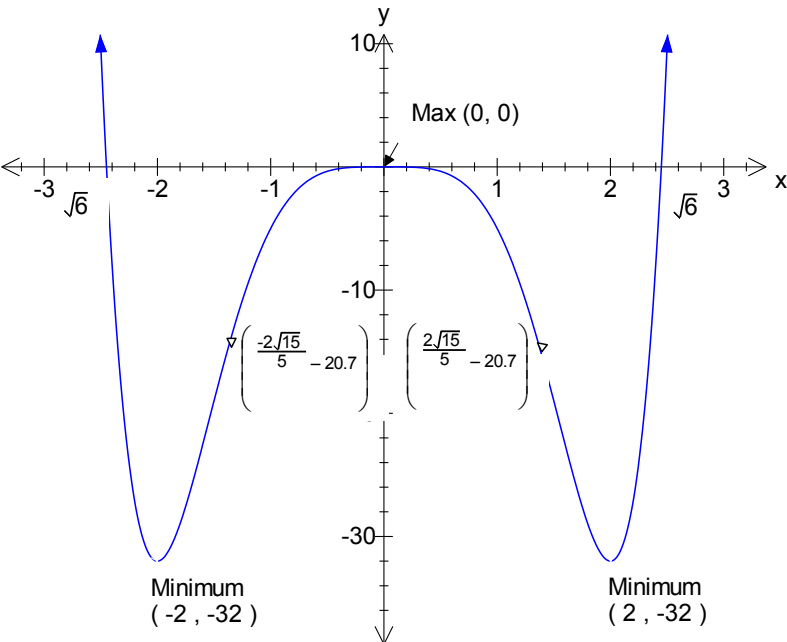
Part	Solution	Marks
(a)(iii)	$y'' = 30x^4 - 72x^2$ $= 6x^2(5x^2 - 12)$ $= 6x^2(\sqrt{5}x - 2\sqrt{3})(\sqrt{5}x + 2\sqrt{3})$ $x = 0 \quad y = 0$ $x = \frac{2\sqrt{3}}{\sqrt{5}} = \frac{2\sqrt{15}}{5} \quad y = -20.736$ $x = -\frac{2\sqrt{3}}{\sqrt{5}} = -\frac{2\sqrt{15}}{5} \quad y = -20.736$ <p>Check for changes of concavity From above, no change at (0, 0) but there is a change at $\left(\pm \frac{2\sqrt{15}}{5}, -20.736\right)$ Inflexions at $\left(\pm \frac{2\sqrt{15}}{5}, -20.736\right)$</p>	2
		2

Question 6		Trial HSC Examination- Mathematics
Part	Solution	Marks
(b)	<p>Stationary points on y occur where $f'(x) = 0$ i.e. at $x = -4$ here $f''(x)$ is positive \therefore min turning point at $x = -4$ and at $x = 2$ here $f''(x)$ is negative \therefore max turning point at $x = 2$ or using first derivative test (explanation or table)</p>	2

Question 7		Trial HSC Examination- Mathematics
Part	Solution	Marks
(a)i)	$\log_a 0.4 = \log_a \frac{2}{5}$ $= \log_a 2 - \log_a 5$ $= x - y$	1
ii)	$\log_a 20 = \log_a (2^2 \times 5)$ $= 2 \log_a 2 + \log_a 5$ $= 2x + y$	2

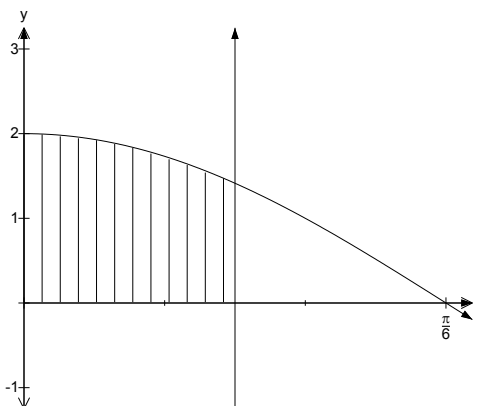
Part	Solution	Marks
b)	<p>$y = 2 \cos 3x$</p>  $\text{Area} = \int_0^{\frac{\pi}{12}} 2 \cos 3x \, dx$ $= \left[\frac{2 \sin 3x}{3} \right]_0^{\frac{\pi}{12}}$ $= \frac{2 \sin \frac{\pi}{4}}{3} - \frac{2 \sin 0}{3}$ $= \frac{2}{3\sqrt{2}} - 0$ $= \frac{\sqrt{2}}{3} \text{ square units.}$	3

(c)i)	<p>Substitute $y = x^2 - 3x$ into $y = 5x - x^2$</p> $5x - x^2 = x^2 - 3x$ $2x^2 - 8x = 0$ $2x(x - 4) = 0$ $x = 0, \quad y = 0$ $x = 4, \quad y = 4$ <p>Intersect at $(0, 0)$ and $(4, 4)$.</p>	2
-------	---	---

ii)

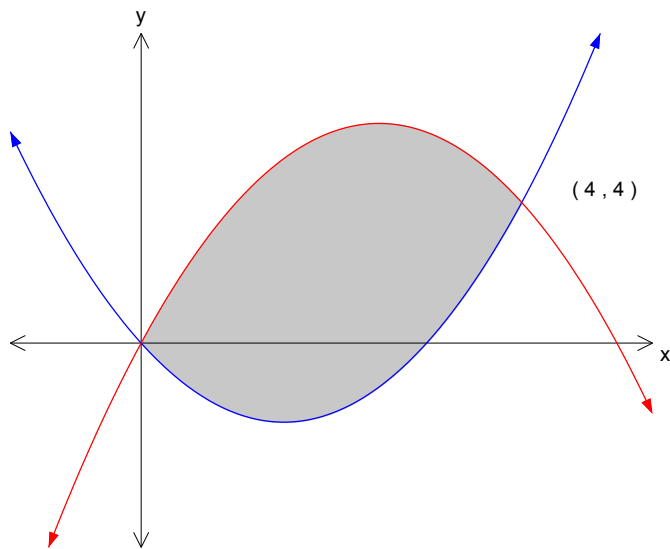

$$\text{Area} = \int_0^4 5x - x^2 dx - \int_0^4 x^2 - 3x dx$$

$$= \int_0^4 8x - 2x^2 dx$$

$$= \left[4x^2 - \frac{2x^3}{3} \right]_0^4$$

$$= \left(64 - \frac{128}{3} \right) - 0$$

$$= \frac{64}{3} = 21\frac{1}{3}$$

3

d)

$$\frac{d}{dx} \log_e (\cos x)$$

$$= \frac{-\sin x}{\cos x}$$

$$= -\tan x$$

Question 8		Trial HSC Examination- Mathematics
Part	Solution	Marks
(a)i)	$P = Ae^{kt}$ $\frac{dP}{dt} = Ae^{kt} \cdot k$ $= kAe^{kt}$ $= kP$	1
ii)	$t = 1$ was 147 200 $P = Ae^{kt}$ $147200 = Ae^k$ (i) $t = 2$ was 154 800 $154800 = Ae^{2k}$ (ii) $\frac{154800}{147200} = \frac{Ae^{2k}}{Ae^k}$ (ii) \div (i) $1.0516 = e^k$ $k = \ln(1.0516)$ $k \approx 0.05$ $147200 = Ae^{0.05(1)}$ $A = \frac{147200}{e^{0.05}} = 139973$	2
iii)	When $t = 4$ $P = Ae^{kt}$ $P = 139973e^{0.05(4)}$ $= 171197$	1
iv)	$P = Ae^{kt}$ $200000 = 139973e^{0.05t}$ $\frac{200000}{139973} = e^{0.05t}$ $1.429 = e^{0.05t}$ $\ln(1.429) = \ln(e^{0.05t})$ $0.05t = \ln(1.429)$ $t = \frac{\ln(1.429)}{0.05}$ $= 7.1$ $t = 7$ is start of 2012 Population will reach 200 000 in 2012	1

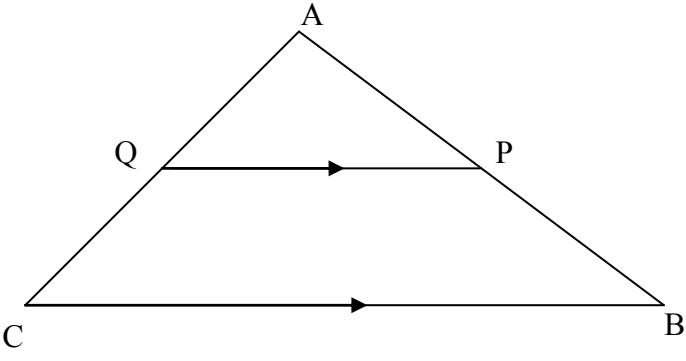
Question 8		Trial HSC Examination- Mathematics
Part	Solution	Marks
(b)i)	 <p>In $\triangle APQ$ and $\triangle ABC$ $\angle A$ is common $\angle AQP = \angle ACB$ (Corresponding \angles on \parallel lines) $\angle APQ = \angle ABC$ (Corresponding \angle on \parallel lines) $\therefore \triangle APQ \parallel \triangle ABC$ (Corresponding angles equal)</p>	2
ii)	$\frac{AP}{AB} = \frac{1}{2} \quad (\text{P is midpoint of AB})$ $\frac{AP}{AB} = \frac{AQ}{AC} \quad (\text{sides of similar triangle in same ratio})$ $\frac{AQ}{AC} = \frac{1}{2} \quad (\text{from above})$ $\therefore Q \text{ is midpoint of AC.}$	2
(c)	$\int_1^3 g(x) dx \approx \frac{1}{6} \{12 + 4(8) + 2(0) + 4(3) + 5\}$ $\approx \frac{61}{6}$ $\approx 10\frac{1}{6}$	2
(d)	$\sum_{n=2}^5 (n^2 - 1) = (2^2 - 1) + (3^2 - 1) + (4^2 - 1) + (5^2 - 1)$ $= 3 + 8 + 15 + 24$ $= 50$	1

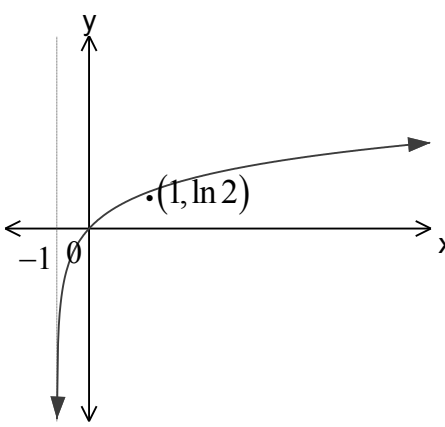
Question 9		Trial HSC Examination- Mathematics
Part	Solution	Marks
(a)	$y = 2x^2 - 2$ $V = \pi \int_0^6 x^2 dy$ $= \pi \int_0^6 \frac{y+2}{2} dy$ $= \pi \left[\frac{y^2}{4} + y \right]_0^6$ $= \pi \left[\left(\frac{36}{4} + 6 \right) - (0) \right]$ $= 15\pi \text{ u}^3$	3
(b)		2
(c)	$\frac{2}{5} \int 5x^4 e^{x^5} dx = \frac{2}{5} e^{x^5} + c$	1
(c)i)	$A_6 = 20000 - 6M$	1
ii)	$A_7 = (20000 - 6M)1.01 - M$ $A_8 = [(20000 - 6M)1.01 - M]1.01 - M$ $= (20000 - 6M)1.01^2 - 1.01M - M$ $= (20000 - 6M)1.01^2 - M(1 + 1.01)$	1
iii)	$A_9 = (20000 - 6M)1.01^3 - M(1 + 1.01 + 1.01^2)$ $A_n = (20000 - 6M)1.01^{n-6} - M(1 + 1.01 + 1.01^2 + \dots + 1.01^{n-7})$ $A_{36} = (20000 - 6M)1.01^{30} - M(1 + 1.01 + 1.01^2 + \dots + 1.01^{29})$	2

Question 9		Trial HSC Examination- Mathematics
Part	Solution	Marks
iv)	<p>Since repaid after 36 months $A_{36} = 0$</p> $(20000 - 6M)1.01^{30} - M(1 + 1.01 + 1.01^2 + \dots + 1.01^{29}) = 0$ $M(1 + 1.01 + 1.01^2 + \dots + 1.01^{29}) = (20000 - 6M)1.01^{30}$ <p>Need to evaluate $1 + 1.01 + 1.01^2 + \dots + 1.01^{29}$</p> <p>Geometric series with $a = 1$, $r = 1.01$, $n = 30$</p> $S_{30} = \frac{a(r^n - 1)}{r - 1}$ $= \frac{1(1.01^{30} - 1)}{1.01 - 1}$ $= 34.785$ $34.785M = (20000 - 6M)1.01^{30}$ $\frac{34.785M}{1.01^{30}} = 20000 - 6M$ $6M + \frac{34.785M}{1.01^{30}} = 20000$ $M\left(6 + \frac{34.785}{1.01^{30}}\right) = 20000$ $31.8M = 20000$ $M = \frac{20000}{31.8}$ $= \$629 \quad (\text{nearest dollar})$	2

Question 10		Trial HSC Examination- Mathematics
Part	Solution	Marks
a) i)	$V = 2 - \sqrt{3} \cos t - \sin t$ $\frac{dV}{dt} = \sqrt{3} \sin t - \cos t$	1
ii)	<p>When $t = 0$</p> $\frac{dV}{dt} = \sqrt{3} \sin 0 - \cos 0$ $= -1$ <p>\therefore the tank is emptying at this time.</p>	1
iii)	<p>Full (or empty) when $\frac{dV}{dt} = 0$</p> $\frac{dV}{dt} = 0$ $\sqrt{3} \sin t - \cos t = 0$ $\sqrt{3} \sin t = \cos t$ $\frac{\sin t}{\cos t} = \frac{1}{\sqrt{3}}$ $\tan t = \frac{1}{\sqrt{3}}$ $= \frac{\pi}{6}, \frac{7\pi}{6}, \frac{13\pi}{6} \dots$ <p>As tank is initially emptying, second value corresponds to when full.</p> <p>Tank is first full when $t = \frac{7\pi}{6}$</p> $V = 2 - \sqrt{3} \cos t - \sin t$ $= 2 - \sqrt{3} \cos \frac{7\pi}{6} - \sin \frac{7\pi}{6}$ $= 4$	3

(b)i)	<p>$\angle D$ is common</p> <p>$\angle C = \angle B = 90^\circ$</p> <p>$\angle E = \angle A$ (corresponding angles on lines)</p> <p>$\triangle ABD \sim \triangle ECD$ (equiangular)</p> $\frac{x+h}{x} = \frac{2t}{2} = t$ $x+h = tx$ $tx - x = h$ $x(t-1) = h$ $x = \frac{h}{t-1}$	2
(b)ii)	$V = \frac{1}{3}\pi(2t)^2 \cdot (h+x) - \frac{1}{3}\pi(2)^2 \cdot x$ $= \frac{1}{3}\pi(2t)^2 \cdot \left(h + \frac{h}{t-1}\right) - \frac{1}{3}\pi(2)^2 \cdot \left(\frac{h}{t-1}\right)$ $= \frac{1}{3}\pi(2t)^2 \cdot \left(\frac{ht}{t-1}\right) - \frac{1}{3}\pi(2)^2 \cdot \left(\frac{h}{t-1}\right)$ $= \frac{1}{3}\pi(2)^2 \cdot \left(\frac{h}{t-1}\right)(t^3 - 1)$ $= \frac{4}{3}\pi \cdot \left(\frac{h}{t-1}\right)(t-1)(t^2 + t + 1)$ $= \left(\frac{4\pi h}{3}\right)(t^2 + t + 1)$	2

iii)

Sum of radii and height = 12

$$2 + h + 2t = 12$$

$$h = 10 - 2t$$

$$V = \left(\frac{4\pi h}{3}\right)(t^2 + t + 1)$$

$$= \left(\frac{4\pi}{3}\right)(10 - 2t)(t^2 + t + 1)$$

$$= \left(\frac{4\pi}{3}\right)(10t^2 + 10t + 10 - 2t^3 - 2t^2 - 2t)$$

$$= \left(\frac{4\pi}{3}\right)(8t^2 + 8t - 2t^3 + 10)$$

$$V = \left(\frac{4\pi}{3}\right)(8t^2 + 8t - 2t^3 + 10)$$

$$\frac{dV}{dt} = \left(\frac{4\pi}{3}\right)(16t + 8 - 6t^2)$$

$$\frac{dV}{dt} = 0$$

$$(16t + 8 - 6t^2) = 0$$

$$6t^2 - 16t - 8 = 0$$

$$3t^2 - 8t - 4 = 0$$

$$t = \frac{-b \pm \sqrt{b^2 - 4ac}}{2a}$$

$$= \frac{8 \pm \sqrt{(-8)^2 - 4(3)(-4)}}{2(3)}$$

$$= \frac{8 \pm \sqrt{112}}{6}$$

$$= -0.43 \text{ or } 3.10 \text{ (to 2 dec pl)}$$

$$t > 0 \text{ so } t = 3.10 \text{ m}$$

$$\frac{d^2V}{dt^2} = \left(\frac{4\pi}{3}\right)(16 - 12t)$$

$$\frac{d^2V}{dt^2} = \left(\frac{4\pi}{3}\right)(16 - 12(3.10)) = \left(\frac{4\pi}{3}\right)(-21.2)$$

$$= -88.7$$

$$\text{When } t = 3.10 \therefore \frac{d^2V}{dt^2} < 0$$

$\therefore V$ is a maximum

$$V = \left(\frac{4\pi}{3}\right)(8(3.10)^2 + 8(3.10) - 2(3.10)^3 + 10)$$

$$= 218.2 \text{ m}^3 \text{ (to 1 dec pl)}$$

3